

DRAWER SLIDE

อุปกรณ์รางลิ้นชัก



CC108 - standard drawer runner

Technical Information

- Assembly under drawer with stability and self-closing
- Static load capacity N294 (Kg 30)
- Double safety stop against involuntary exit of drawer
- Automatic closure during last 60 mm.
- Finish : epoxy coat : white
- Size: 30, 35, 40, 45, 50, 55, 60 cm.



ข้อมูลทางเทคนิค

- รางลิ้นชักอย่างดี รับผิดชอบ SELF-CLOSING
- กันการไหลกลับของลิ้นชัก
- ลูกล้อในล่อน้อย่างดี ไม่แตกง่าย
- ปิดได้เงียบสนิท ไม่เกิดเสียงดัง
- เคลือบ EPOXY สีขาว
- รับน้ำหนัก 30 กก.
- ยาว 30, 35, 40, 45, 50, 55, 60 ซม.

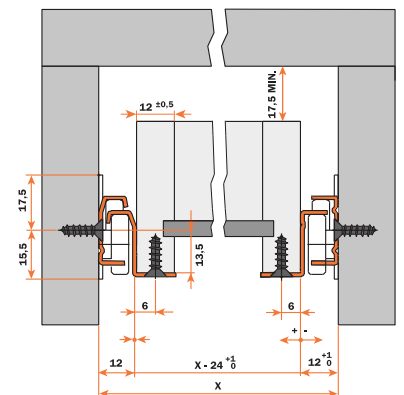
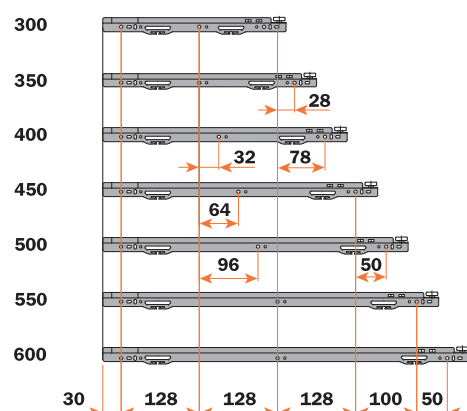
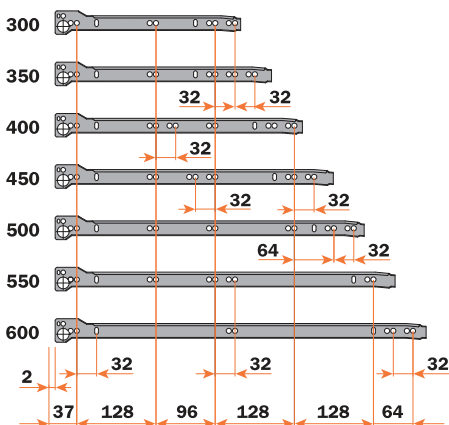

DRAWER SLIDE

อุปกรณ์รางลิ้นชัก



TE-FB - drawer slide

Technical Information

- Full Extension drawer slide
- Material in metal and finishing in zinc plating
- Weight 45 k.g.
- Size : 30/35/40/45/50/55/60 cm.

ข้อมูลทางเทคนิค

- รางลิ้นชักถูกป็นแบบรับข้าง สามารถดึงออกได้ตลอด
- โลหะชุบซิงค์และสีดำ
- รับน้ำหนัก 45 ก.ก.
- ขนาด : 30/35/40/45/50/55/60 ซม.

* Optional

- มีแบบความกว้าง 35 มม. และ 45 มม. แบบสองตอน (สามารถดึงออกได้ตลอด)
- มีแบบความกว้าง 27 มม. (ยาว 10-20 นิ้ว) และ 17 มม. (ยาว 10-18 นิ้ว) แบบตอนเดียว

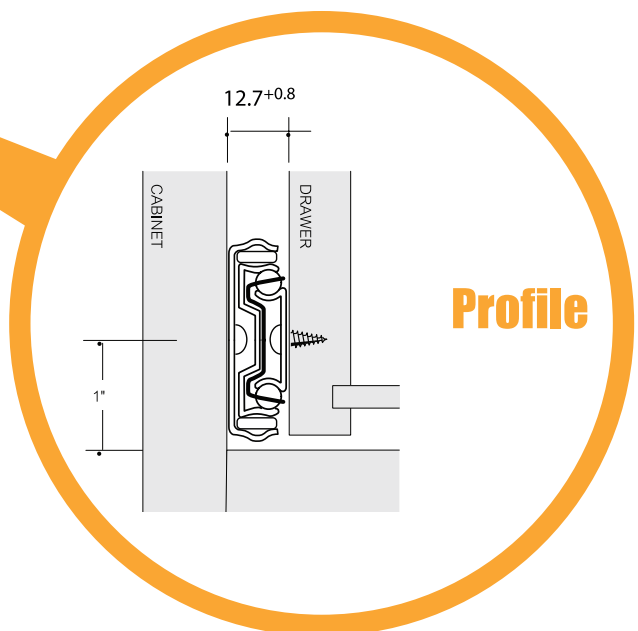

Profile

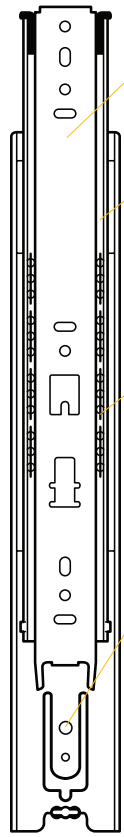

Lever Disconnect
Séparation à l'aide d'un levier
Desconexión de palanca

Telescopic Action
Mouvement télescopique
Acción telescópica

Precision Ball Bearings
Nilles de roulement de précision
Cojinete de bolas de precisión

Direct Access Mounting Holes
Trous de montage à accès direct
Agujero de montaje de acceso directo

Drawer Release Lever

Montage du tiroir coulissant - vue longitudinale / Perfil de la instalación de las correderas de gavetas

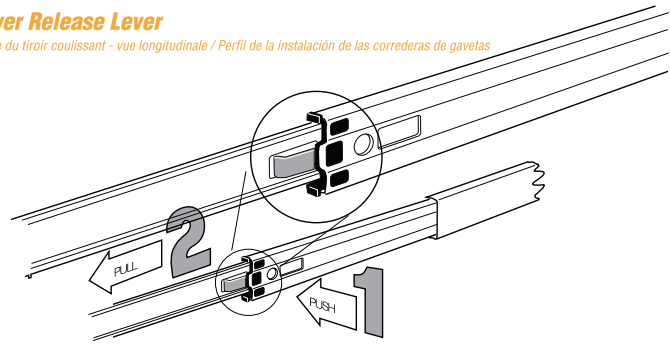

DRAWER SLIDE

อุปกรณ์รางลิ้นชัก



KV 470 / SOFT CLOSING - drawer slide

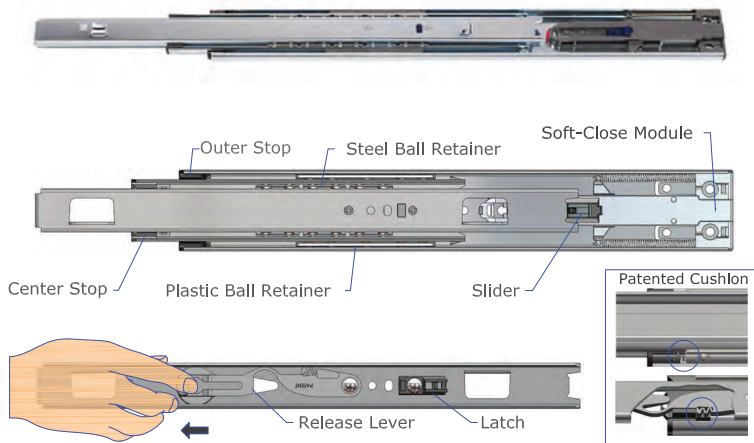

Technical Information

- Runner with soft application
- Material in metal and finishing in zinc plating
- Full Extension drawer slide
- Weight 45 k.g.
- Size : 30/35/40/45/50/55/60 cm.

ข้อมูลทางเทคนิค

- รางลิ้นชักถูกป็นแบบรับข้าง สามารถดึงออกได้ตลอด
- ระบบปิดเบา และนุ่มนวล
- โดหะชุบซิงค์
- รับน้ำหนัก 45 กก.
- ขนาด : 30/35/40/45/50/55/60 ซม.

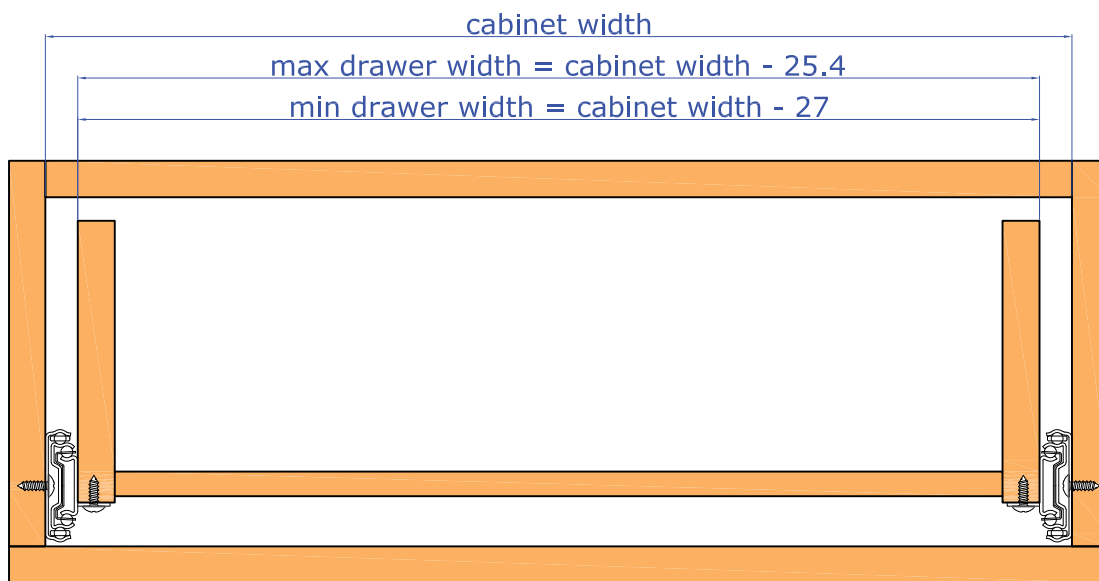

* max drawer width = slide length + 200 (mm)

APPLICATIONS:

For use in wood pedestals, dresser, desk, casework, residential and kitchen cabinetry.

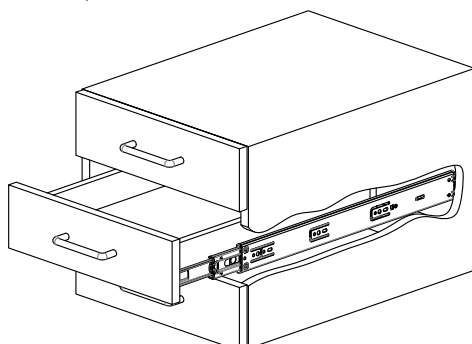

38mm stroke of Soft-Closing

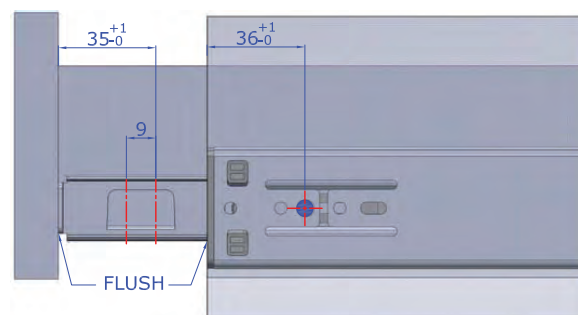

KNAPE & VOGT
HIGH QUALITY FROM USA

DRAWER SLIDE

อุปกรณ์รางลิ้นชัก



KV 460 / PUSH OPENING - drawer slide

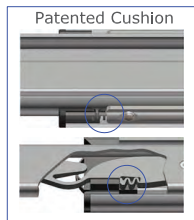
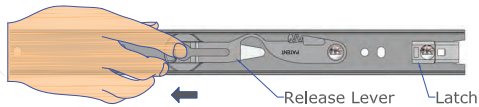
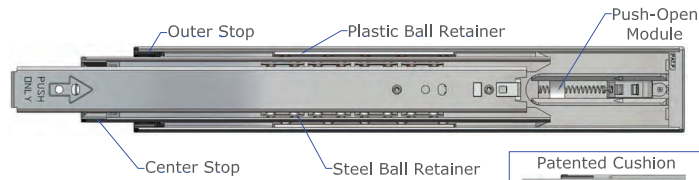

Technical Information

- Runner with push application
- Material in metal and finishing in zinc plating
- Full Extension drawer slide
- Weight 45 k.g.
- Size : 30/35/40/45/50/55/60 mm.

ข้อมูลทางเทคนิค

- รางลิ้นชักลูกปืนแบบรับข้าง สามารถดึงออกได้ตลอด
- ระบบ กดกระเดื่อง
- โลหะชุบสังกะสี
- รับน้ำหนัก 45 ก.ก.
- ขนาด : 30/35/40/45/50/55/60 มม.

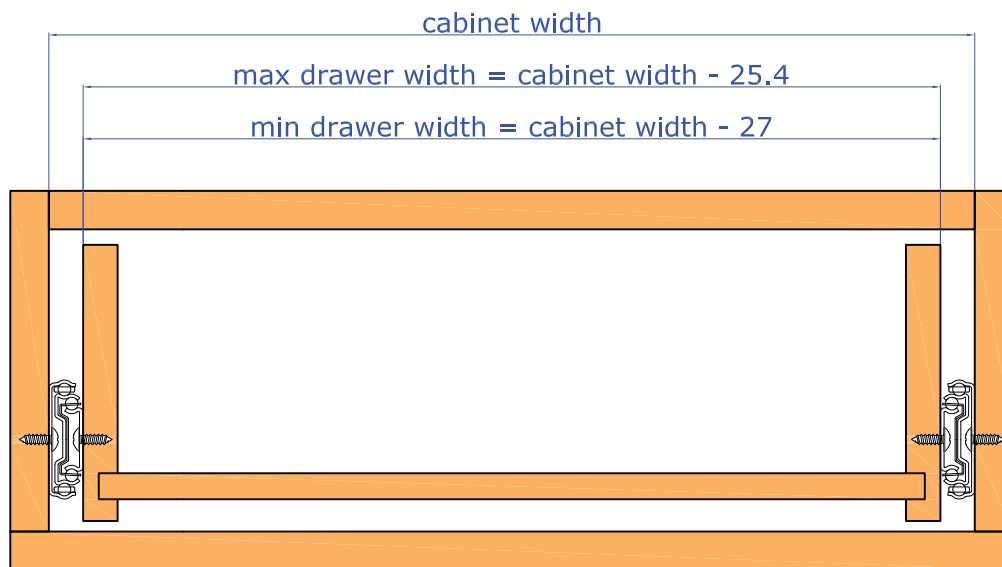

* max drawer width = slide length + 200 (mm)

APPLICATIONS:

For use in wood pedestals, dresser, desk, casework, residential and kitchen cabinetry.

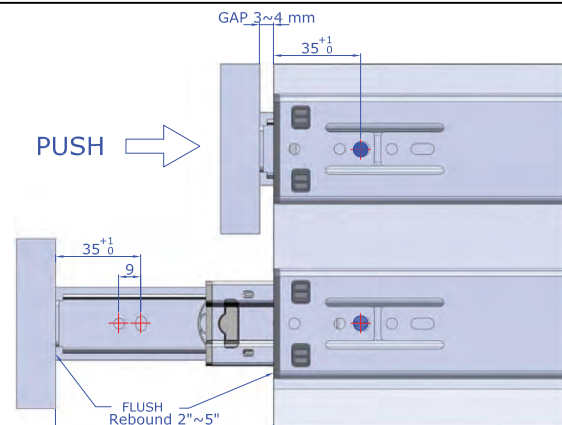
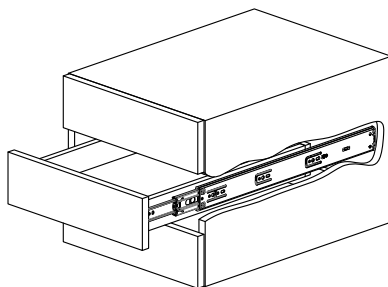

DRAWER SLIDE

อุปกรณ์รางลิ้นชัก



KV 824 - pivot door slides

Technical Information

- 30-pound maximum per door.
- Designed to mount to side of case for pocket door mode. For the flipper mode, door retracts inside of case.
- Maximum door dimension of 24" wide x 42" high
- Self-closing three-way adjustable geometric door hinge with single lever disconnect feature.
- Precision steel ball bearings.
- Large follower strip mounting plate for rigidity and installation ease.
- Bright electro-zinc plated and lacquered finish standard. Optional Ebony Black electro-zinc plated lacquer finish.

ข้อมูลทางเทคนิค

- โลหะเคลือบอย่างดี (สีดำ กับสีซิงค์)
- รับน้ำหนัก 15-20 กก. ต่อ 1 บาน
- รางระบบลูกปืนอย่างดีพร้อมตัวบังคับบาน
- เสียงเงียบใช้งานลื่น คล่องตัว
- มีแผ่นเหล็กฉากรองรับแผ่นระหว่างราง ซึ่งติดตั้งง่ายมาก ช่วยกระชับบานให้แข็งแรง ไม่โคลงเคลง

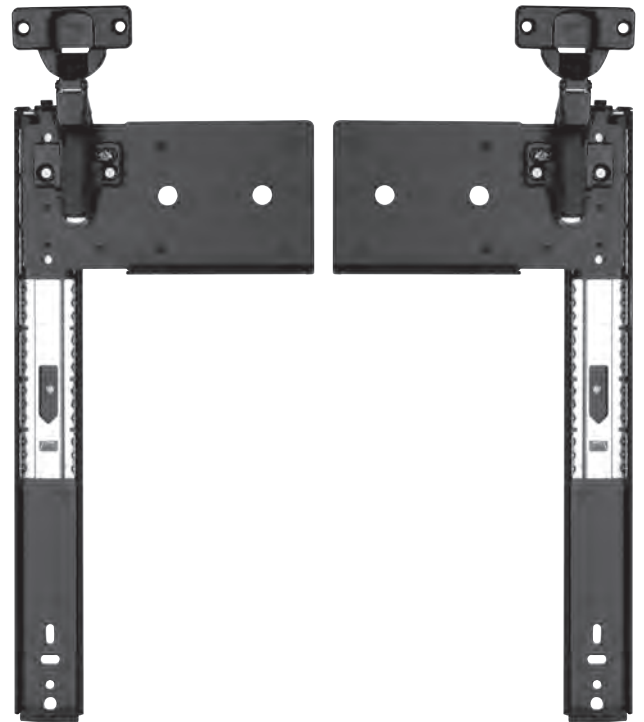

Profile

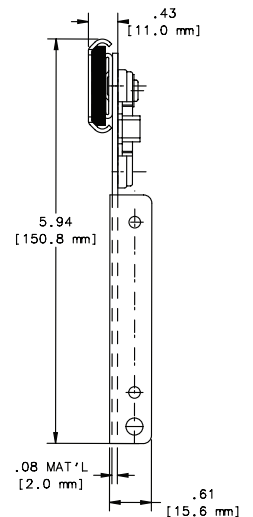

Hinge Configuration

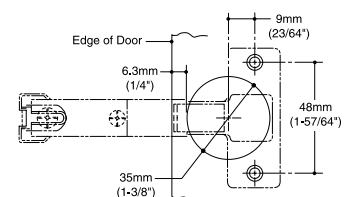

DRAWER SLIDE

อุปกรณ์รางลิ้นชัก

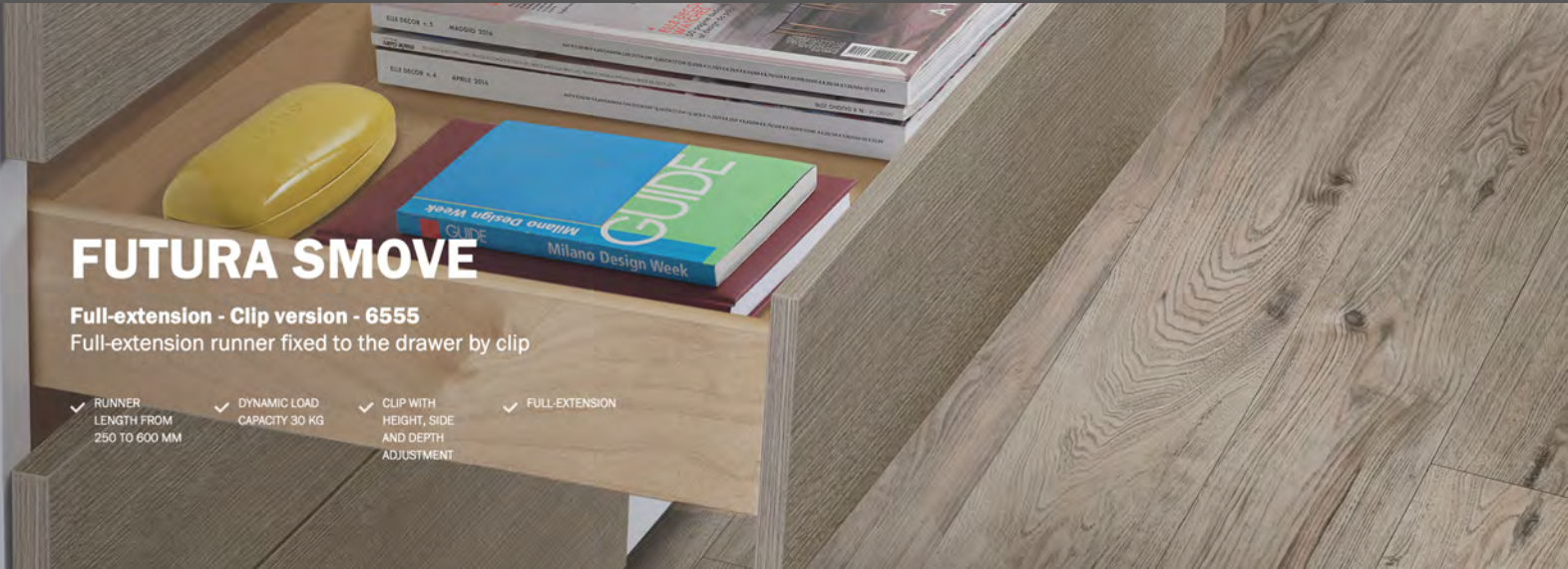

FUTURA SMOVE

Full-extension - Clip version - 6555
Full-extension runner fixed to the drawer by clip

- ✓ RUNNER LENGTH FROM 250 TO 600 MM
- ✓ DYNAMIC LOAD CAPACITY 30 KG
- ✓ CLIP WITH HEIGHT, SIDE AND DEPTH ADJUSTMENT
- ✓ FULL-EXTENSION



CC6555 - futura Smove

Technical Information

- Dynamic load capacity N 294 (kg 30).
- With smove decelerated closing
- Safety system that prevents the drawers from turning over.
- Drawer height adjustment (+2,5mm).
- The drawer is maintained parallel with the cabinet side during opening.
- Finish: bright zinc-plated.
- Size : 25/30/35/40/45/50/55/60 cm.

ข้อมูลทางเทคนิค

- รางลิ้นชักแบบซ่อนราง (สองตอน) อย่างดี
- ระบบ Smove (Soft-closing) ปิดเปิดนุ่มนวล ไม่มีเสียงดัง
- ระบบ "คลิป" ไม่ต้องใช้สกรู รับน้ำหนัก 30 กก.
- สามารถปรับความสูงของลิ้นชัก (+3 มม) ปรับตรงคลิป
- ขนาด : 25/30/35/40/45/50/55/60 ซม.

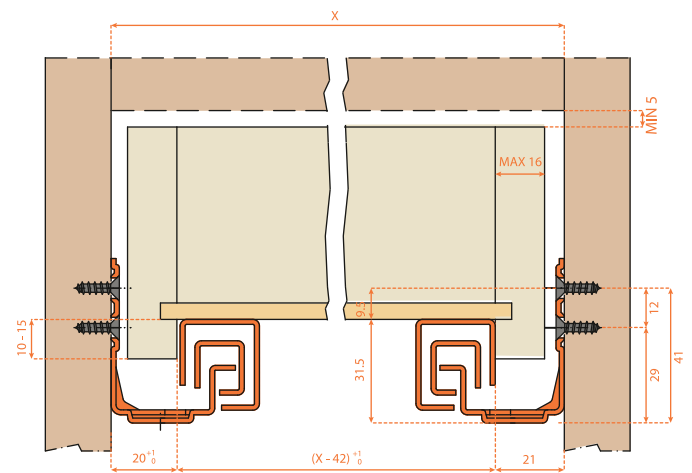
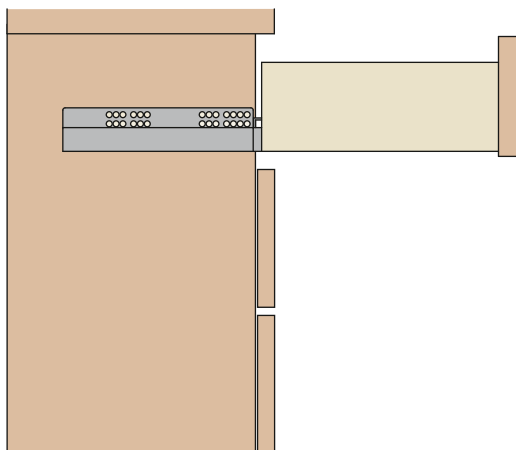

DRAWER SLIDE

อุปกรณ์รางลิ้นชัก



FUTURA PUSH

Full-extension - Clip version - 6557
Full-extension runner fixed to the drawer by clip

- ✓ RUNNER LENGTH FROM 250 TO 600 MM
- ✓ DYNAMIC LOAD CAPACITY 30 KG
- ✓ CLIP WITH HEIGHT, SIDE AND DEPTH ADJUSTMENT
- ✓ FULL-EXTENSION

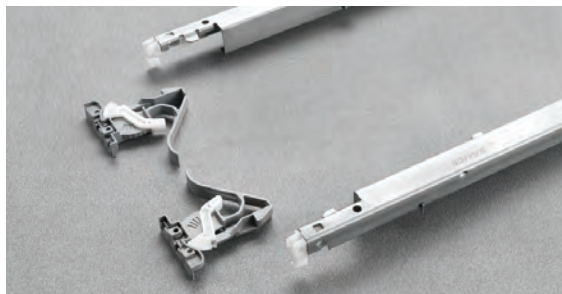

CC6557 - futura Push

Technical Information

- Dynamic load capacity N 294 (kg 30).
- With Push opening system.
- Safety system that prevents the drawers from turning over.
- Drawer height adjustment (+2,5mm).
- The drawer is maintained parallel with the cabinet side during opening.
- The drawer is held in the closed position and requires positive effort to open it.
- Finish: bright zinc-plated.
- Size : 30/35/40/45/50/55/60 cm.

ข้อมูลทางเทคนิค

- รางลิ้นชักแบบซ่อนราง (สองตอน) อย่างดี
- ระบบ Push (Self-opening) เพียงกดและเปิดตัวเองอย่างนุ่มนวล
- ระบบ "คลิป" ไม่ต้องใช้สกรู รับน้ำหนัก 30 กก.
- สามารถปรับความสูงของลิ้นชัก (+3 มม) ปรับตรงคลิป
- ขนาด : 30/35/40/45/50/55/60 ซม

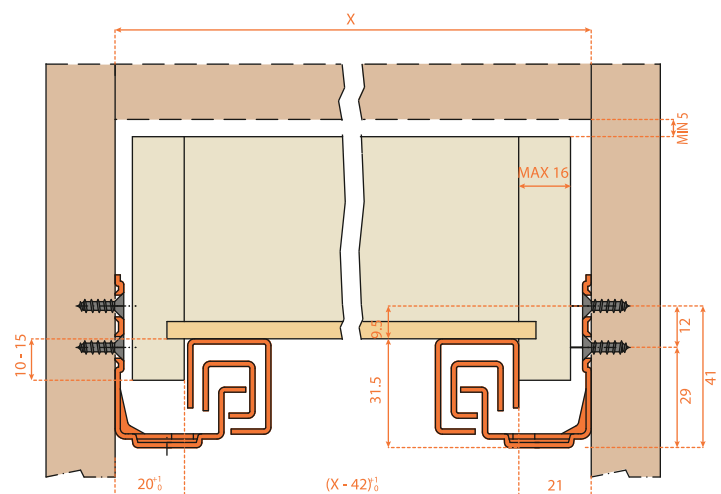
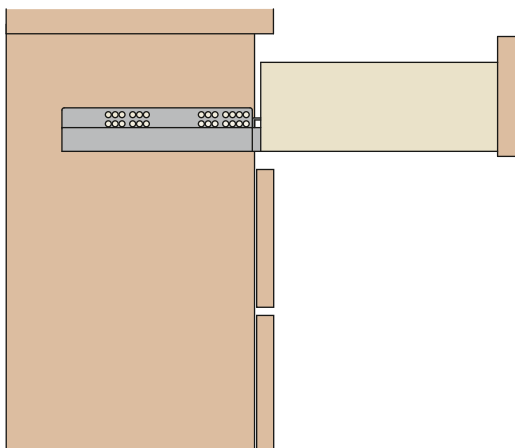

DRAWER SLIDE

อุปกรณ์รางลิ้นชัก



CC6555 , CC6557 Fixing

Fixing full-extension runner on cabinet side.

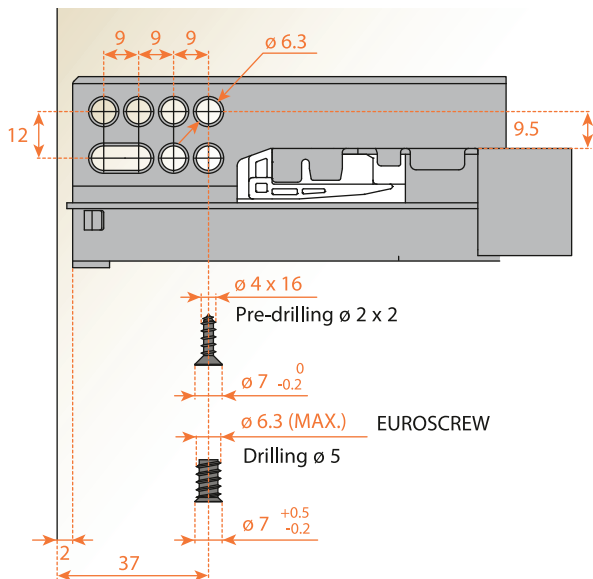

The oval slot allows the easy alignment of drawer frontals particularly in multi drawer and Push applications.

Drilling positions for runner on cabinet side. Full-extension

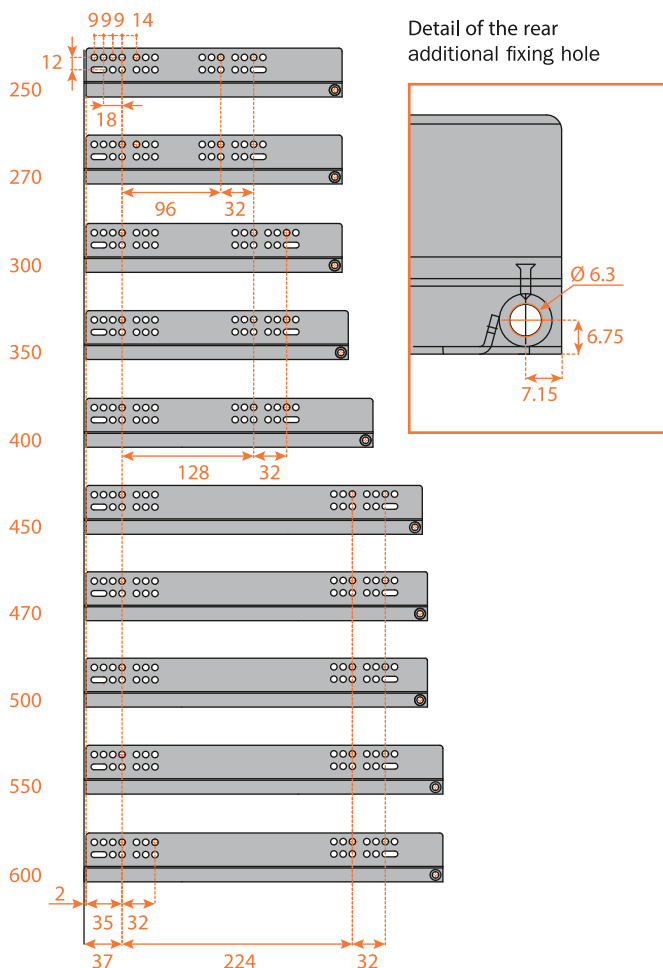

DRAWER SLIDE

อุปกรณ์รางลิ้นชัก



Clip version - Drawer setting

Abbreviations

- SP = Thickness of the drawer
- LN = Nominal runner length
- PM = Depth of the cabinet
- X = Internal width of the cabinet

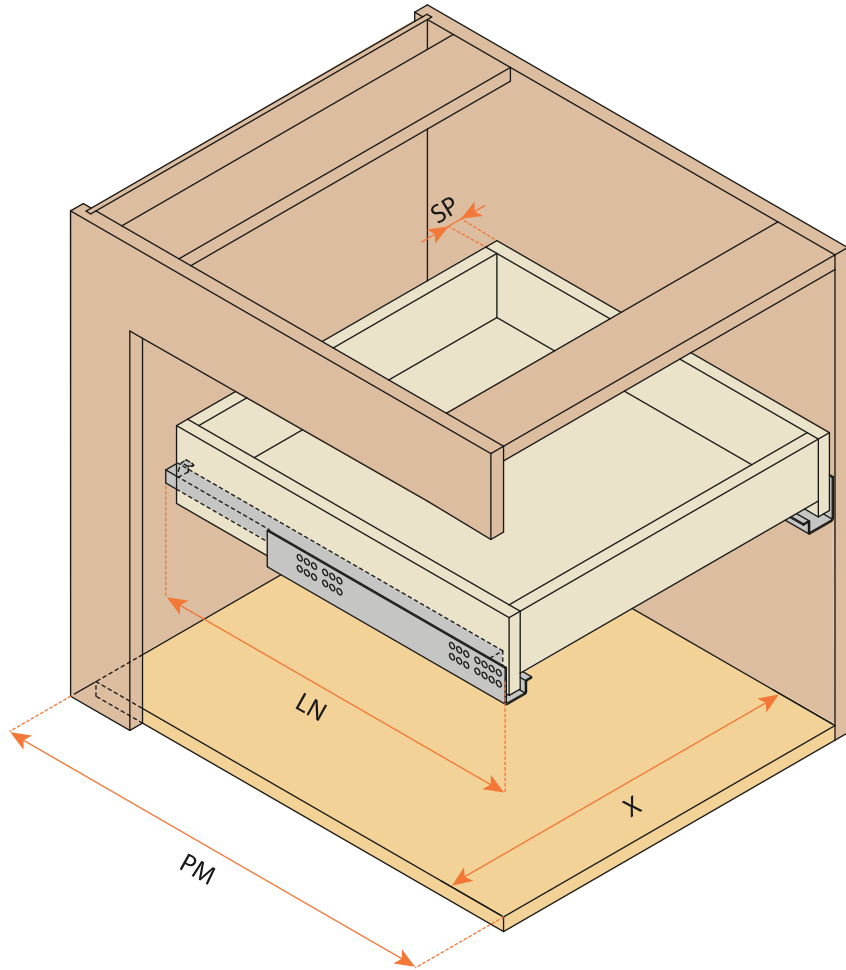

Drawer dimensions

- LC = Runner length - 10 mm
- X - 42 = Internal width of the drawer

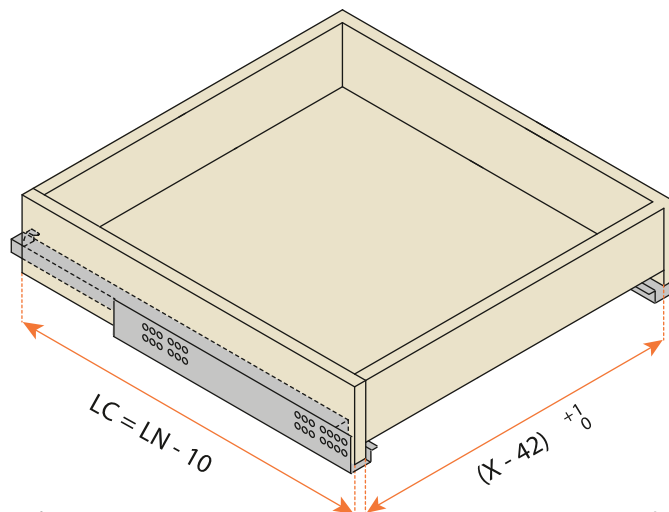

The drawer length is 10 mm shorter than the runner length

The internal width of the drawer is 42 mm less than the internal width of the cabinet

DRAWER SLIDE

อุปกรณ์รางลิ้นชัก



Futura - Clip - Drawer drilling

Drawer with frontal - three-sided (view from below)
Template for drawer drilling - see page 60

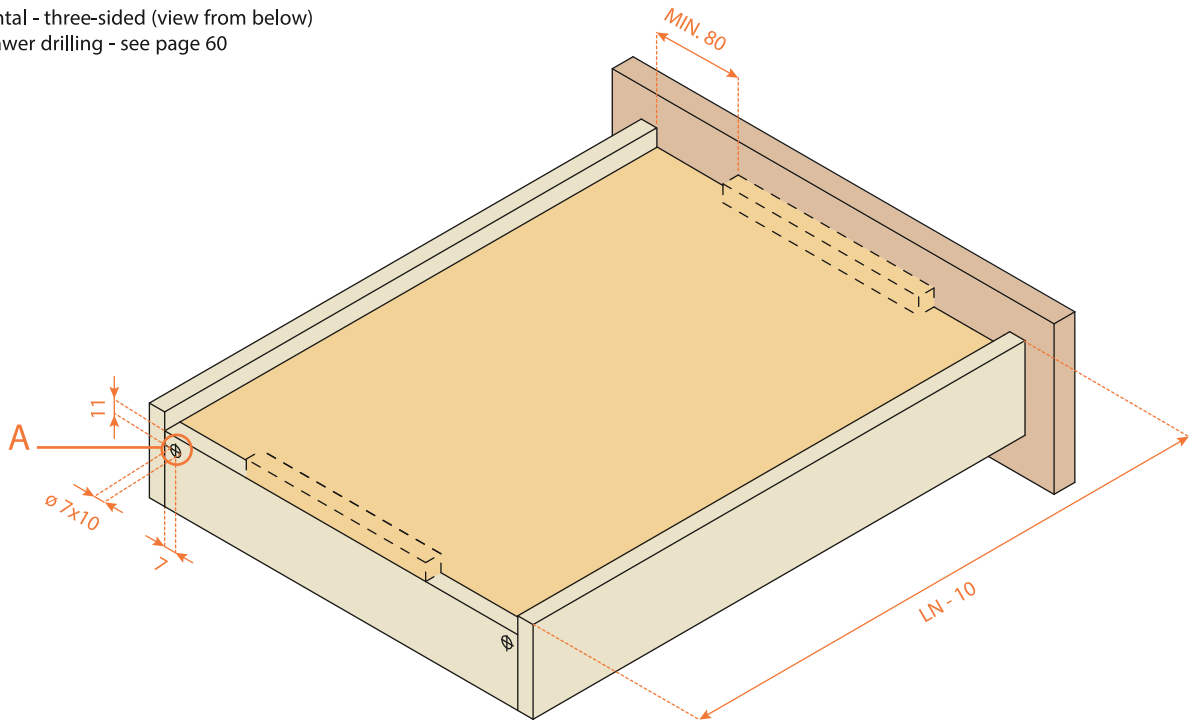

Internal drawer - four-sided (view from below)
Template for drawer drilling - see page 60

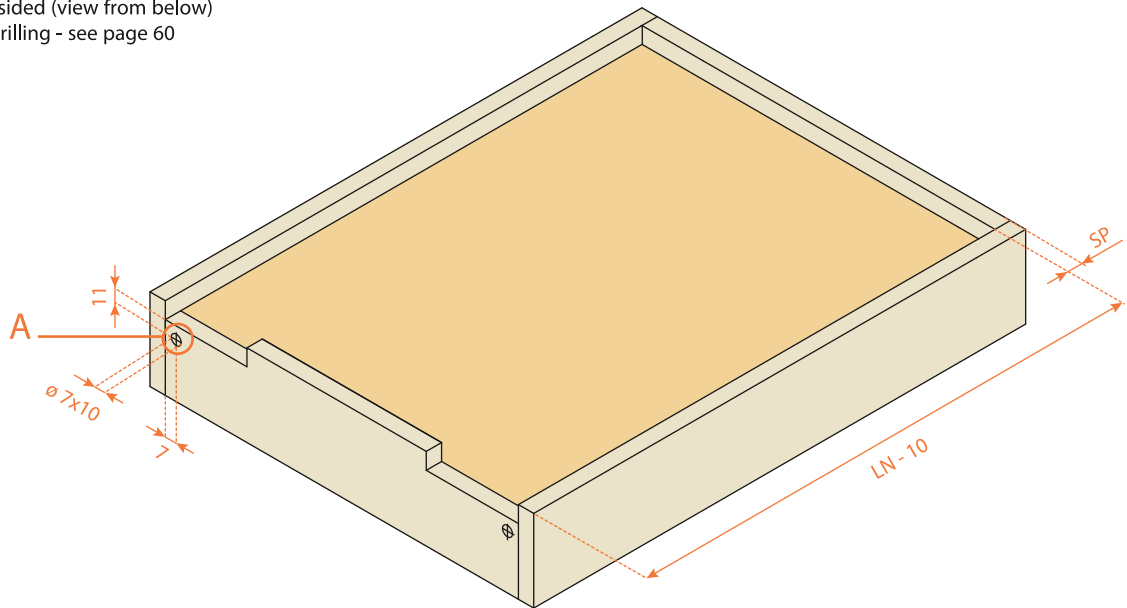

REAR HOOK

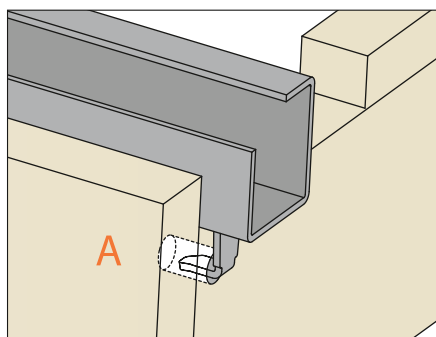

Use drilling template for rear hook,

REAR NOTCH

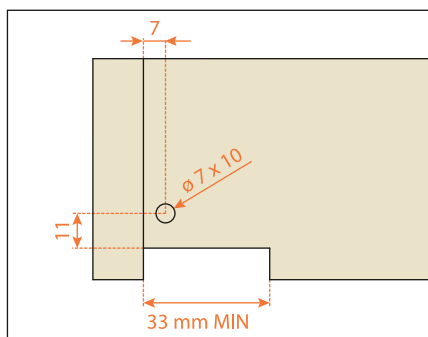

REAR NOTCH
with Futura Push synchroniser

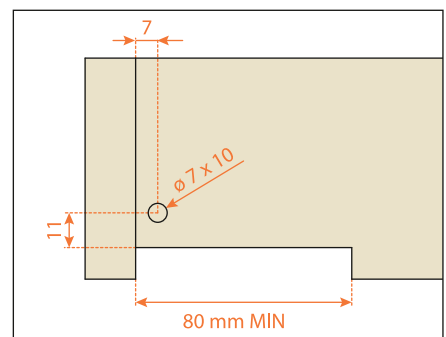

DRAWER SLIDE

อุปกรณ์รางลิ้นชัก



UNICA

Full-extension - Clip version - 6558
Full-extension runner system fixed to the drawer by clip

- ✓ INTEGRATED PUSH SYSTEM
- ✓ AUTOMATED SMOVE SYSTEM
- ✓ RUNNER LENGTH FROM 300 TO 500 MM
- ✓ CLIP WITH HEIGHT, DEPTH AND SIDE ADJUSTMENT
- ✓ FULL-EXTENSION



CC6558 - futura Push - Smove 2 SYSTEM IN 1 DRAWER SLIDE

Technical Information

- Dynamic load capacity N 294 (kg 30).
- With push opening and smove decelerated closing system
- Safety system that prevents the drawers from turning over.
- Drawer height adjustment (+2,5mm).
- The drawer is maintained parallel with the cabinet side during opening.
- Finish: bright zinc-plated.
- Size : 30/35/40/45/50/55/60 cm

ข้อมูลทางเทคนิค

- รางลิ้นชักแบบซ่อนราง (สองตอน) อย่างดี
- ระบบเปิดกดกระดิ่ง (Push-opening) และระบบปิดนุ่มนวล (Soft-closing)
- ระบบ "คลิป" ไม่ต้องใช้สกรู รับน้ำหนัก 30 กก.
- สามารถปรับความสูงของลิ้นชัก (+3มม) ปรับตรงคลิป
- ขนาด : 30/35/40/45/50/55/60 ซม

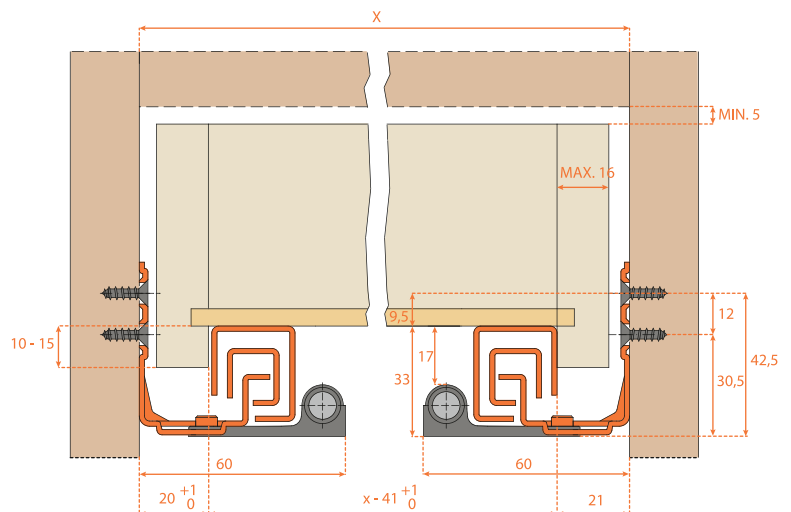
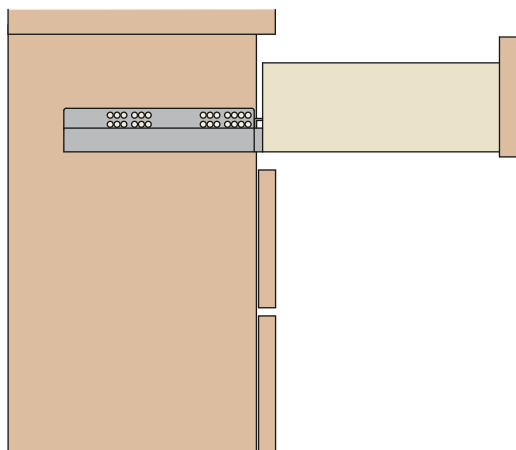

DRAWER SLIDE

อุปกรณ์รางลิ้นชัก



CC6558 Handle-less opening

Push the frontal to open the drawer.



The drawer opens approximately 5 - 10 cm.



Open the drawer to access the inner space.



Open drawer.



Closing with decelerating effect.



Opening with handle

Pull the handle to open the drawer.



Open drawer.



Closing with decelerating effect.



DRAWER SLIDE

อุปกรณ์รางลิ้นชัก



CC6558 Fixing full-extension runner on cabinet side.

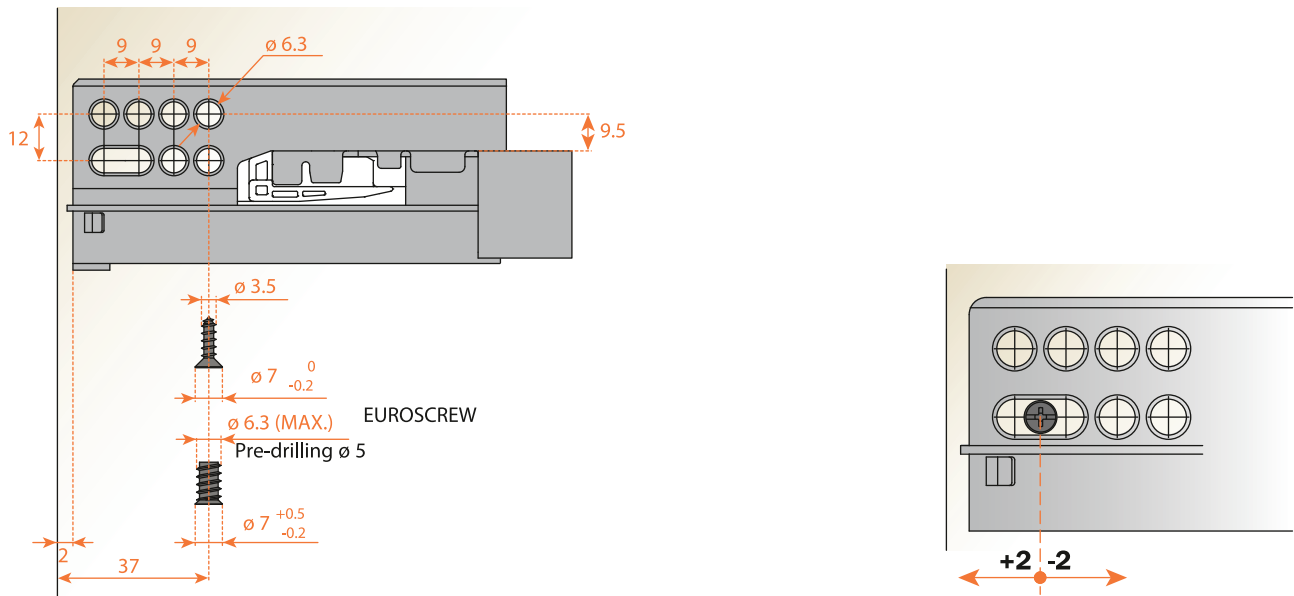

The oval slot allows the easy alignment of drawer frontals particularly in multi drawer and Push applications.

Drilling positions for runner on cabinet side. Full-extension

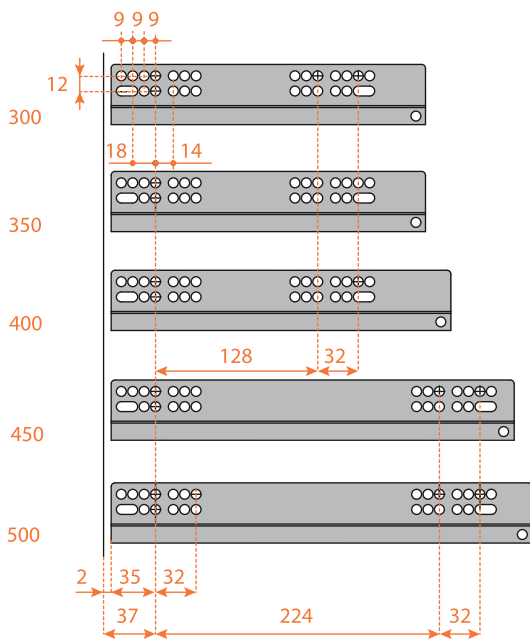

For the function Push is required an A value = 2,5 mm.
This value is obtained by placing the runner at 37 mm from the edge of the cabinet.

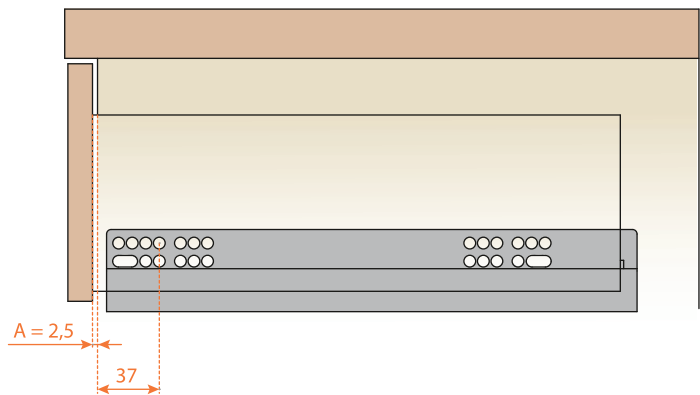

Detail of the rear additional fixing hole

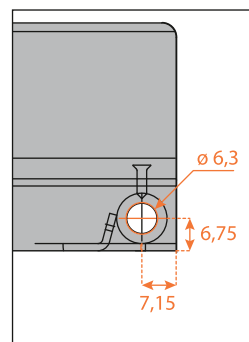

DRAWER SLIDE

อุปกรณ์รางลิ้นชัก



CC6558 Drawer setting: abbreviations

Chest of drawers

SP = Thickness of the drawer

LN = Nominal runner length

PM = Depth of the cabinet

X = Internal width of the cabinet

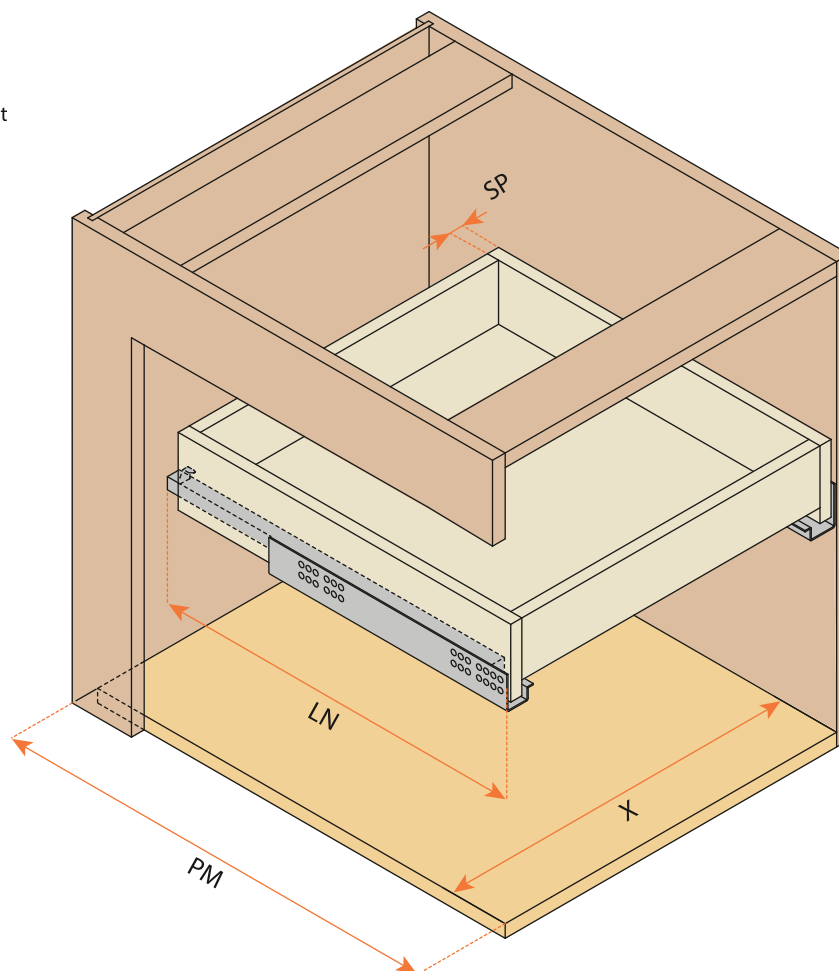

Drawer dimensions

LC = Runner length - 10 mm

X - 41 = Internal width of the drawer

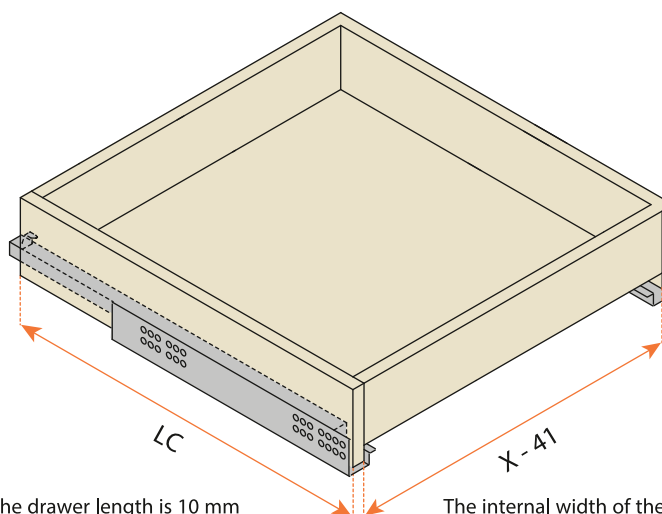

The drawer length is 10 mm shorter than the runner length

The internal width of the drawer is 41 mm less than the internal width of the cabinet

DRAWER SLIDE

อุปกรณ์รางลิ้นชัก



CC70 SMOVE

Full-extension

Its features and distinctive elements make it a complete runner, suitable to meet all needs

- ✓ LOAD CAPACITY UP TO 70 KG
- ✓ FULL EXTENSION
- ✓ COMPATIBLE WITH DRAWER DIVIDERS
- ✓ FINISH BRIGHT UNCOATED



CC70 SMOVE

new heavy-duty
high-capacity drawer runner

Full-extension with synchronised movement of the sliding elements to guarantee lateral stability and a perfectly silent sliding movement

Load capacity up to 70 KG

Full-Extension

Available length 500 mm.

Smove Decelerated closing with 50 mm.

Dimensions

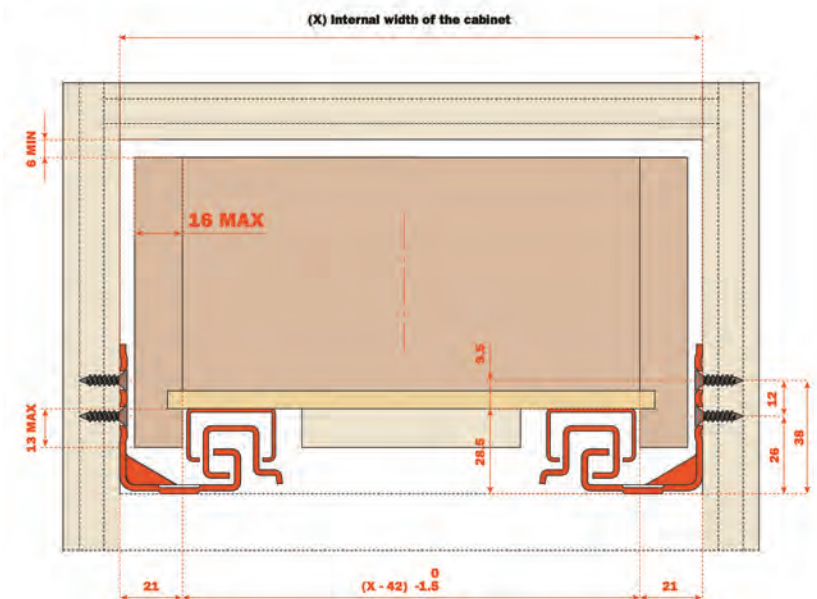

CC70 SMOVE Drawer setting

Abbreviations

CHEST OF DRAWERS

SP = Thickness of the drawer side

LC = Depth of the drawer

PM = Depth of the cabinet

X = Internal width of the cabinet

LN = Nominal runner length

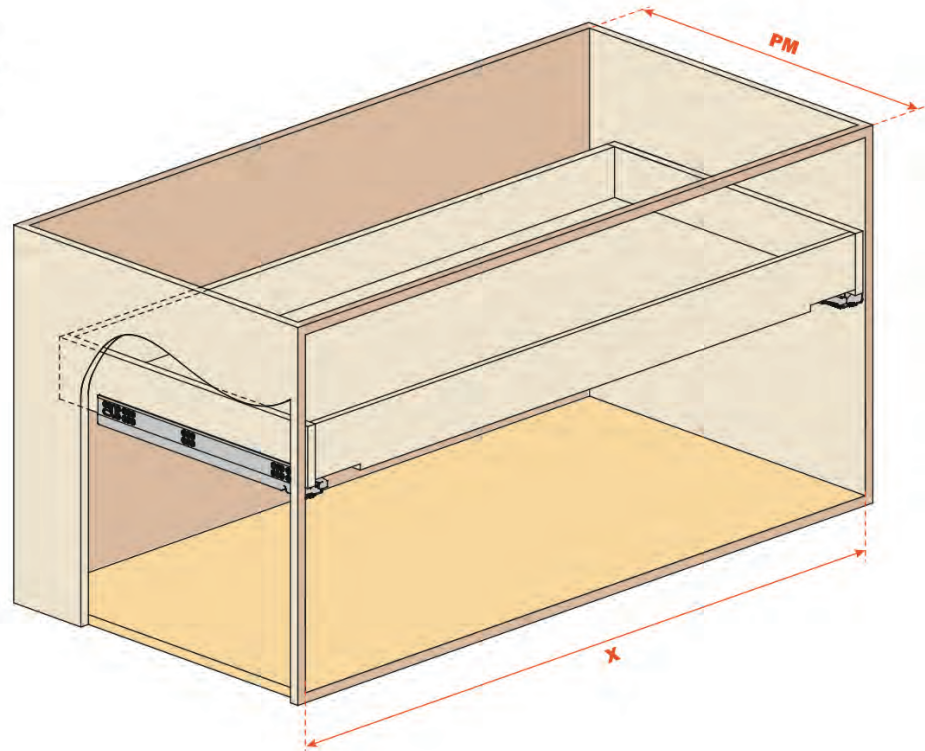

The internal width of the drawer is 42 mm less than the internal width of the cabinet

The external length of the drawer is 10 mm less than the runner length

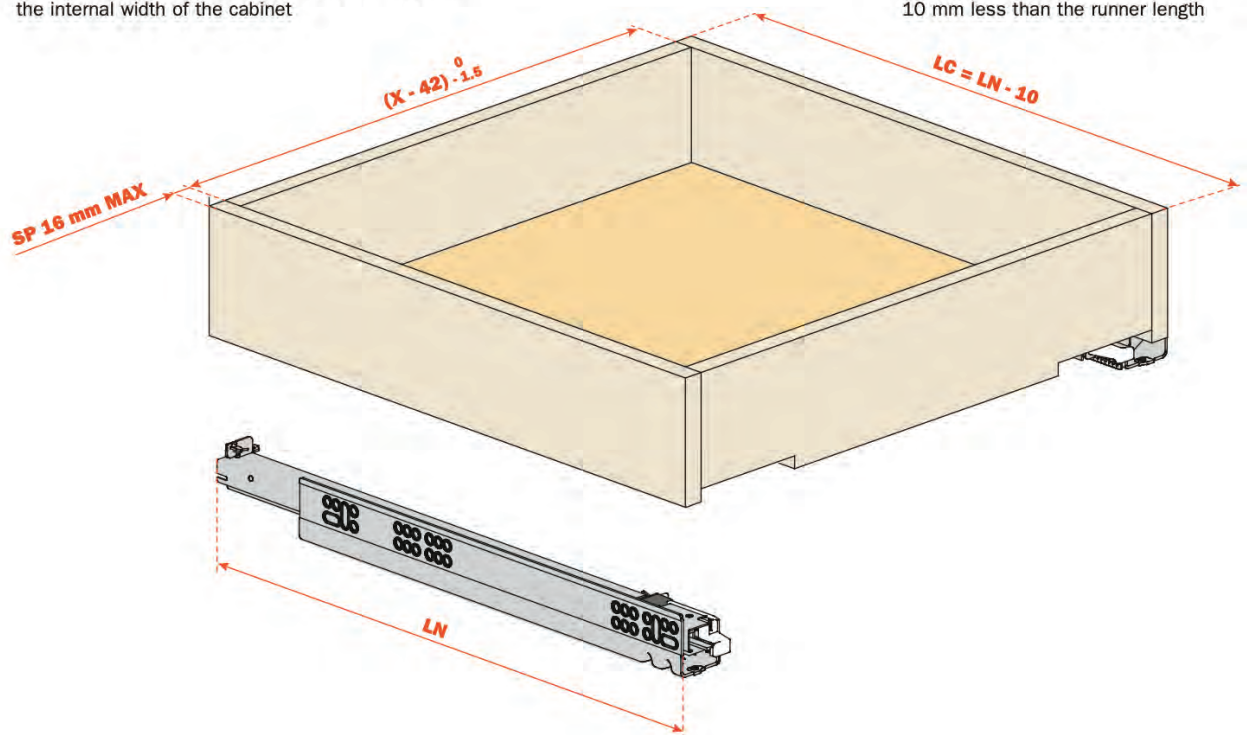

DRAWER SLIDE

อุปกรณ์รางลิ้นชัก



CC70 SMOVE

Drawer drilling

3-SIDED drawer

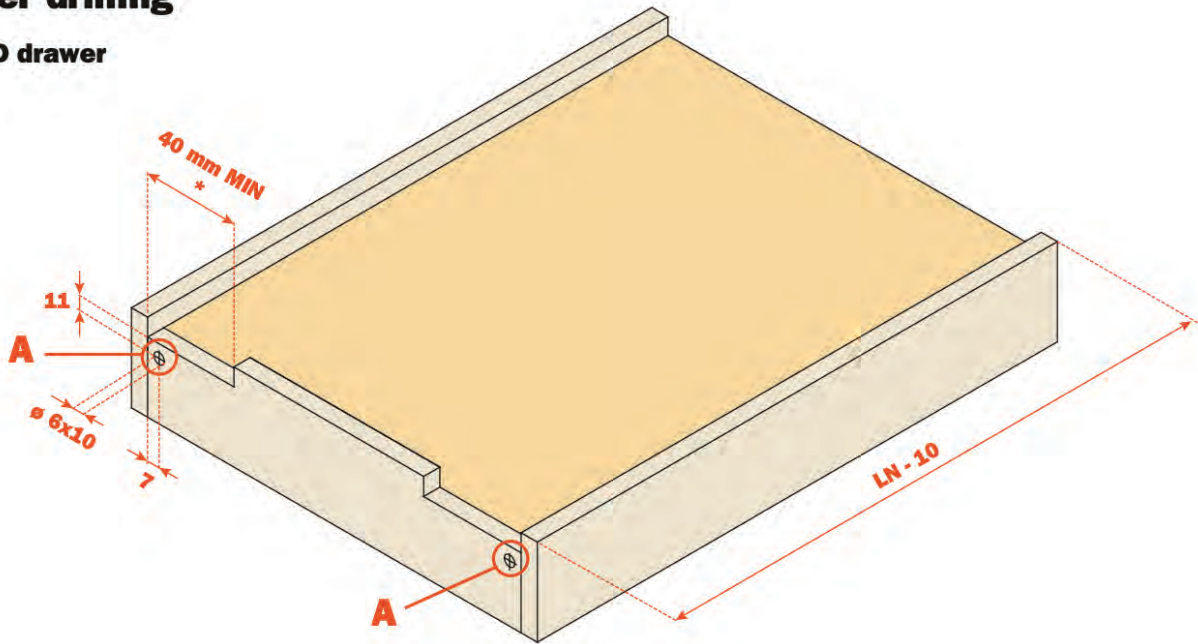

4-SIDED drawer

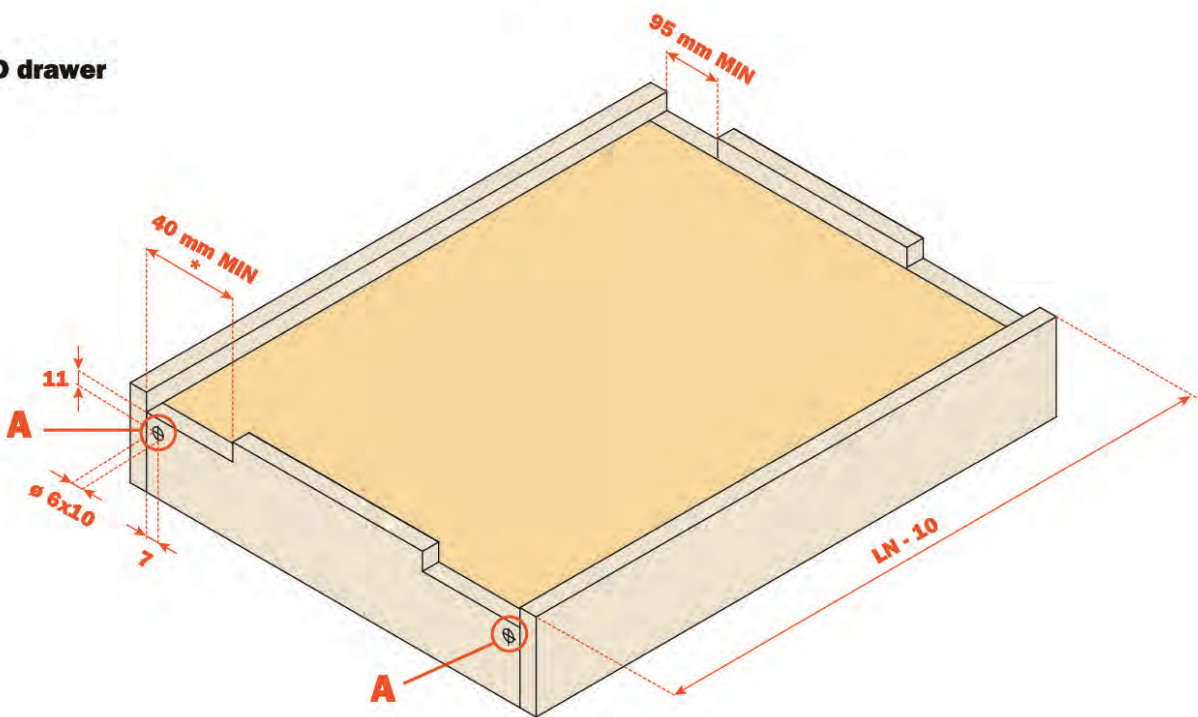

DRAWER SLIDE

อุปกรณ์รางลิ้นชัก



CC 65559 - futura Shelf Smove
 CC 65579 - futura Shelf Push



Technical Information

- Dynamic load capacity N 294 (Kg 30).
- **Smove closing** or **Push opening** system.
- Safety system that prevents the shelves from turning over.
- Shelf height adjustment +2.5 mm.
- The shelf is held in the closed position.
- Finish: bright zinc-plated.

ข้อมูลทางเทคนิค

- รับน้ำหนัก 30 กก.
- มีให้เลือก 2 ระบบคือ **ปิดแบบนุ่มนวล** หรือ **แบบกดกระดิ่ง**
- พร้อมระบบป้องกันการคว่ำของชั้น
- สามารถปรับระดับความสูง +2.5 มม.

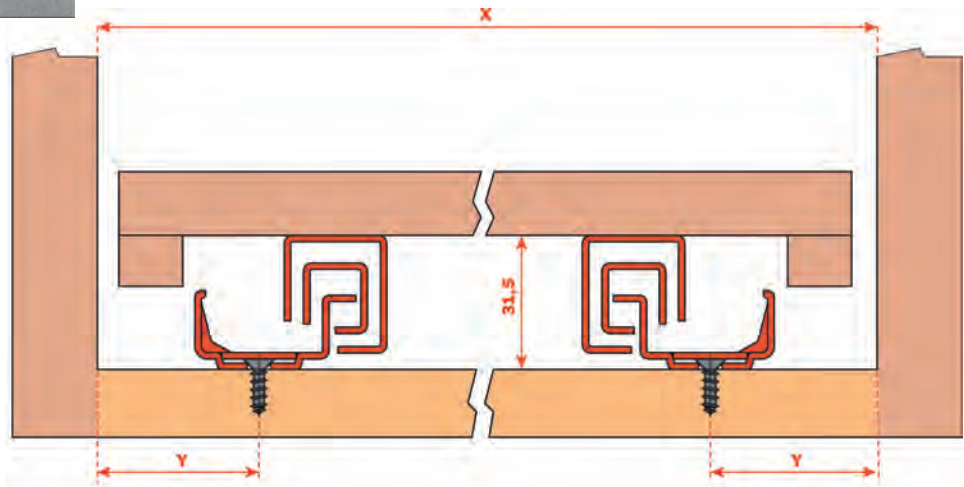
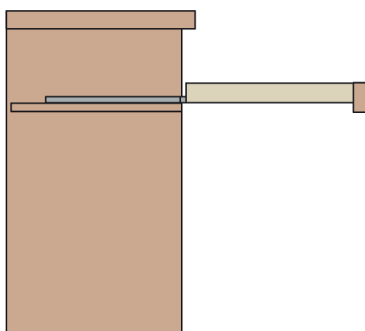

Y = Min. 15 mm

DRAWER SLIDE

อุปกรณ์รางลิ้นชัก



With 1 way adjustable clip
Fixing clip

- Technical information

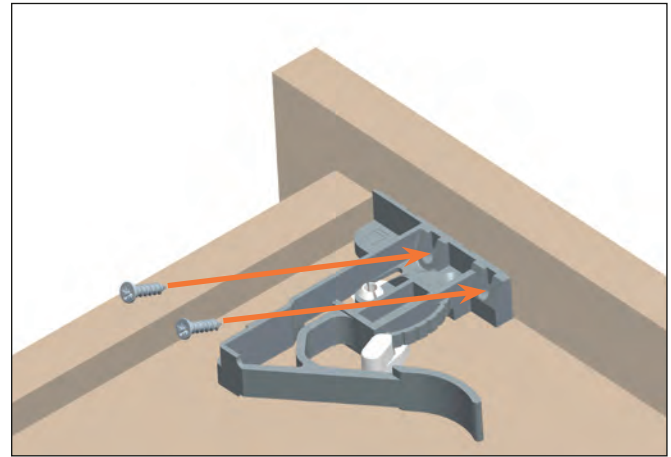
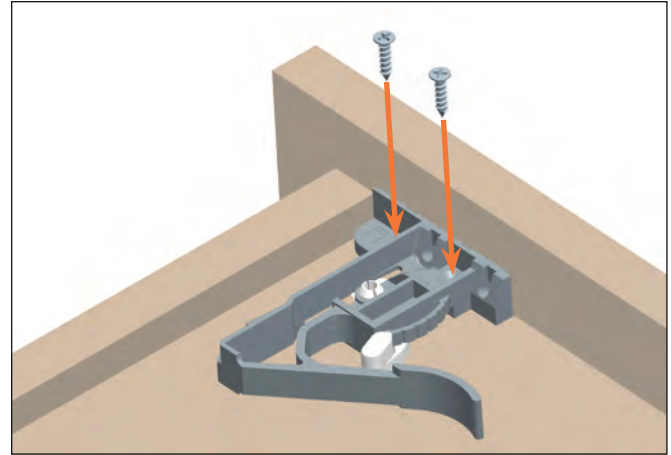
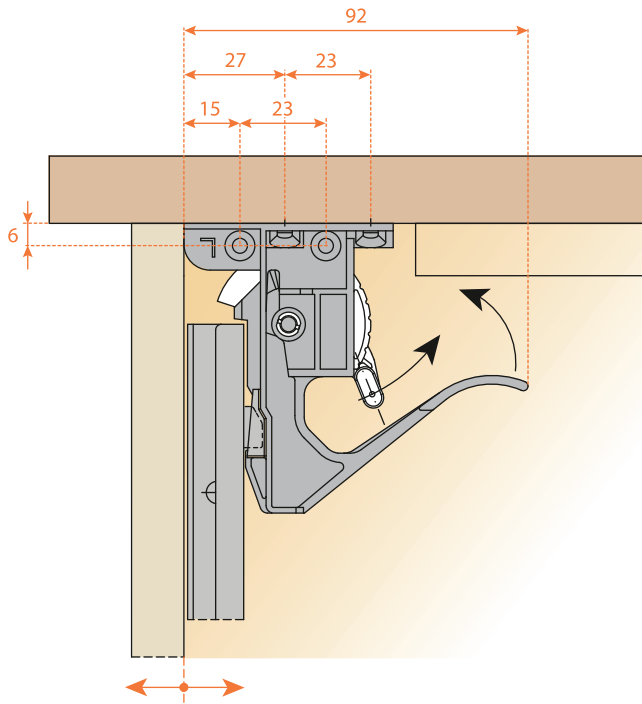

Right and left clip

Height adjustment + 2.5 mm

Turn the lever towards the front of the drawer to adjust the height.

This operation is tool free.

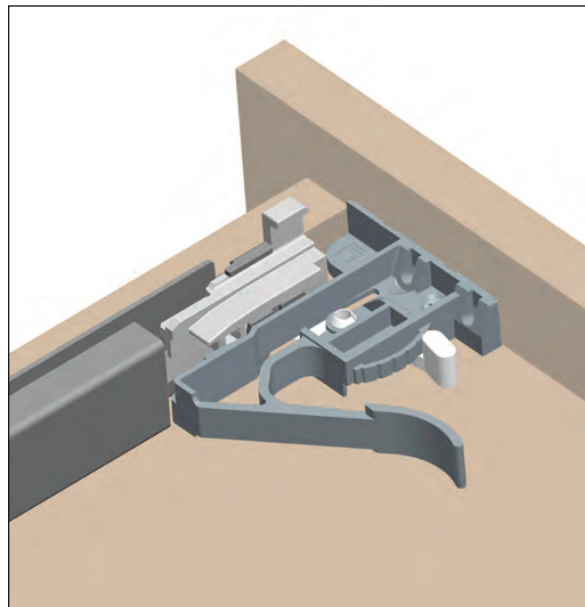
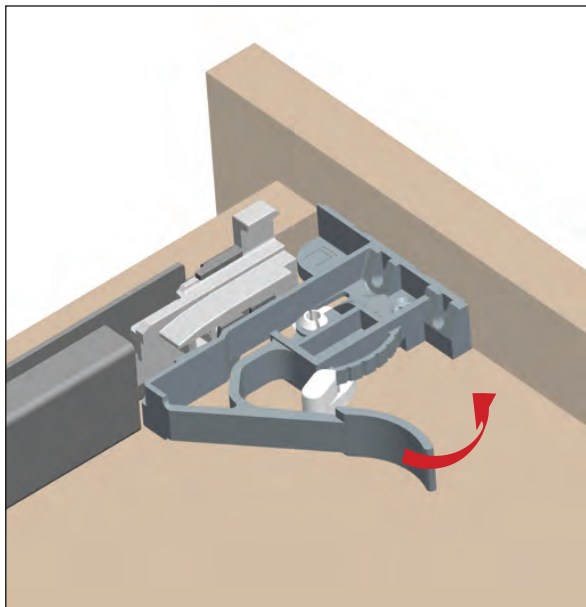

Futura - with 3 way adjustable clip

The 3 way adjustment allows to:

- align the drawers between them;
- align the drawers with the cabinet.

Features and benefits of the clip:

- for all versions of full-extension runners
- tool free 3 way adjustment
- patented removal system of the drawer, from both the front and the sides of the drawer
- clip manufactured in Carbon Fibre rich material for light weight, strength and rigidity

Clip assembly

Position the left and the right clip at the front of the drawer.

Fix with the screws on the bottom or on the front of the drawer as indicated in the images below.

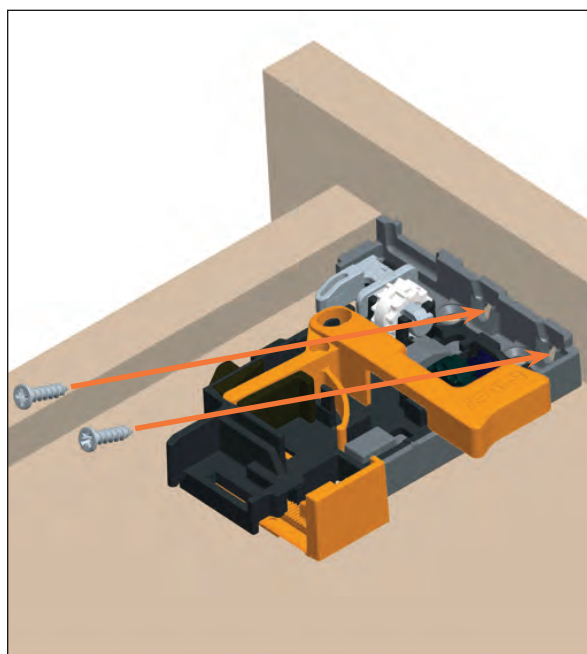
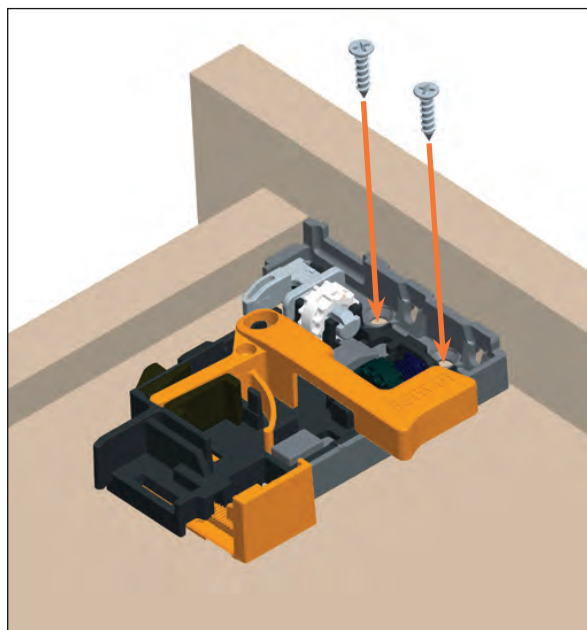
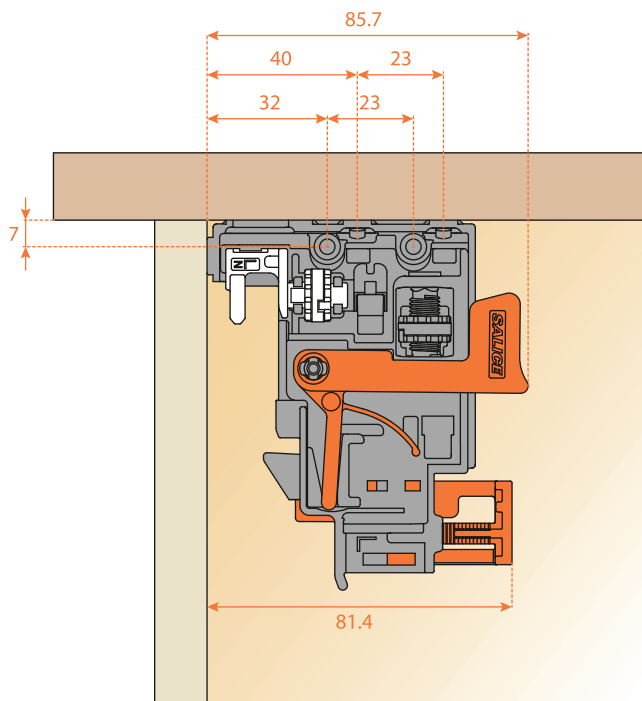

Right and left clip with integrated adjustments

Removal of the drawer

The drawer can be removed operating from both the front and the sides.

Removal from the front:

position the hands under the front of the drawer and pull both the orange levers in the direction indicated , sliding the drawer outwards.

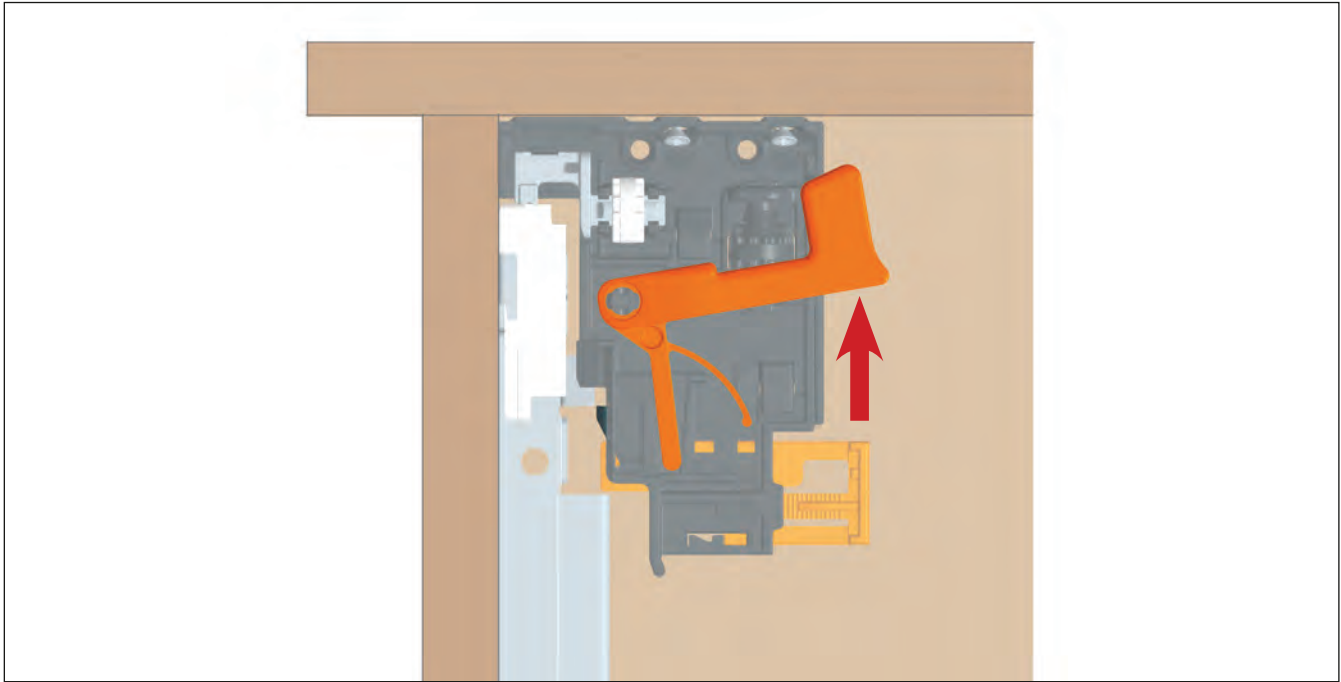

Removal from the side:

position the hands under both sides of the drawer and operate on the orange levers, as indicated in the drawing, sliding the drawer forward.

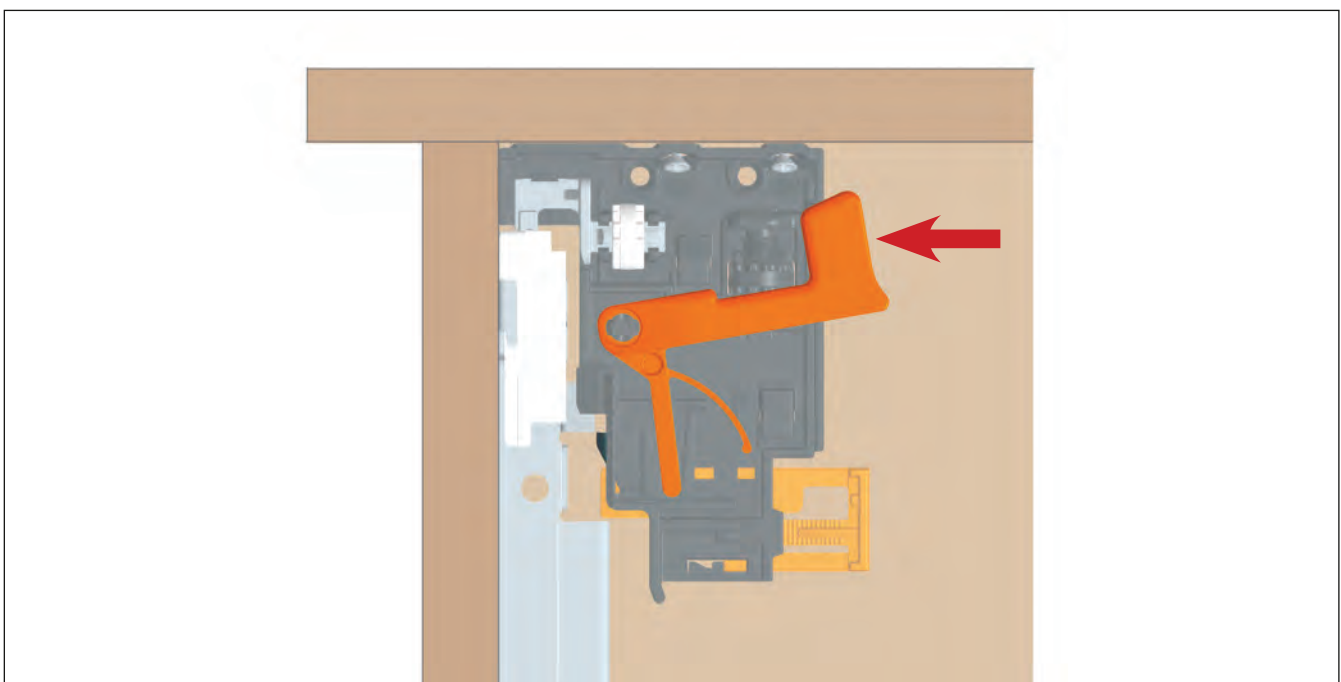

DRAWER SLIDE

อุปกรณ์รางลิ้นชัก



Futura - with 3 way adjustable clip

Height adjustment + 2.5 mm

Initial position of the lever for the height adjustment.

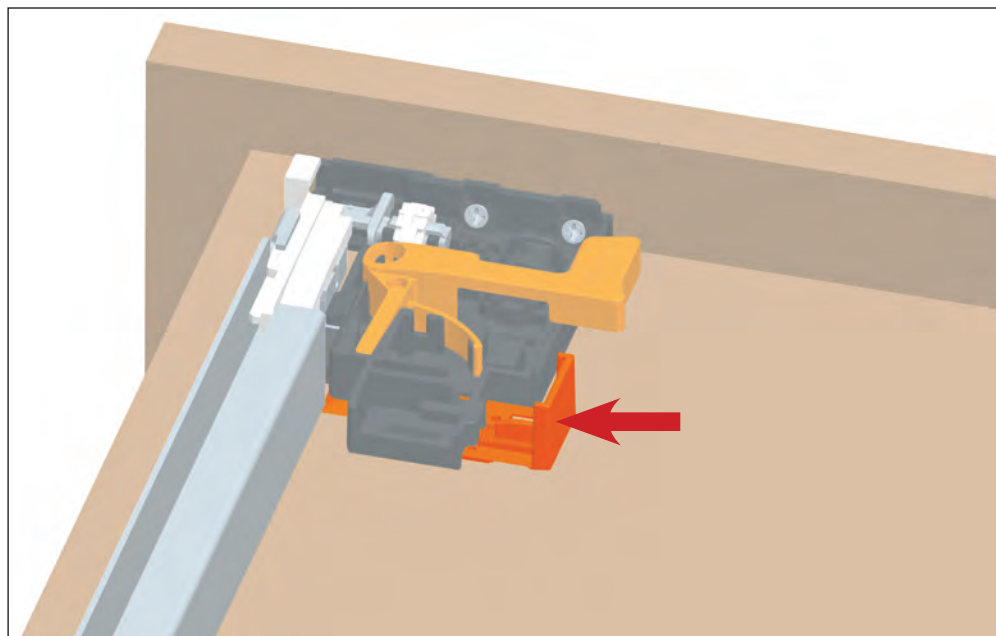
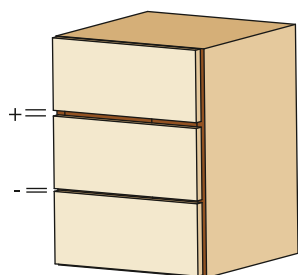

Push the lever towards the outside of the drawer to achieve the height adjustment.

This operation is tool free.

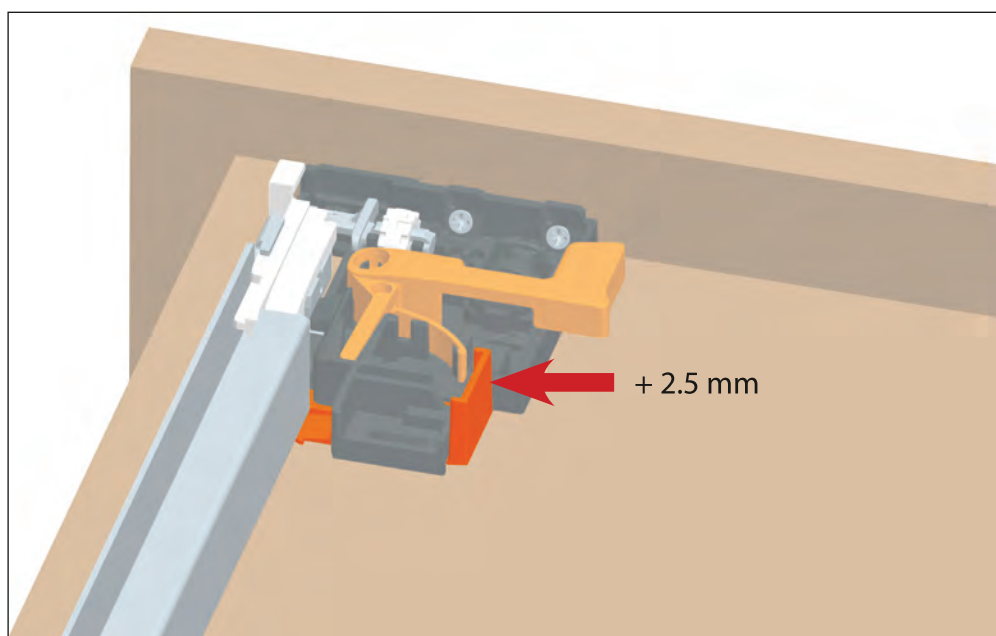
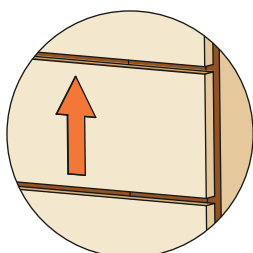
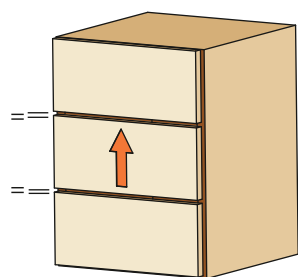

DRAWER SLIDE

อุปกรณ์รางลิ้นชัก



Sideways adjustment + 1.5 mm - 1.5 mm

Rotate the white wheel towards the front of the drawer to adjust left.
The clip shows the position 0.

This operation is tool free.

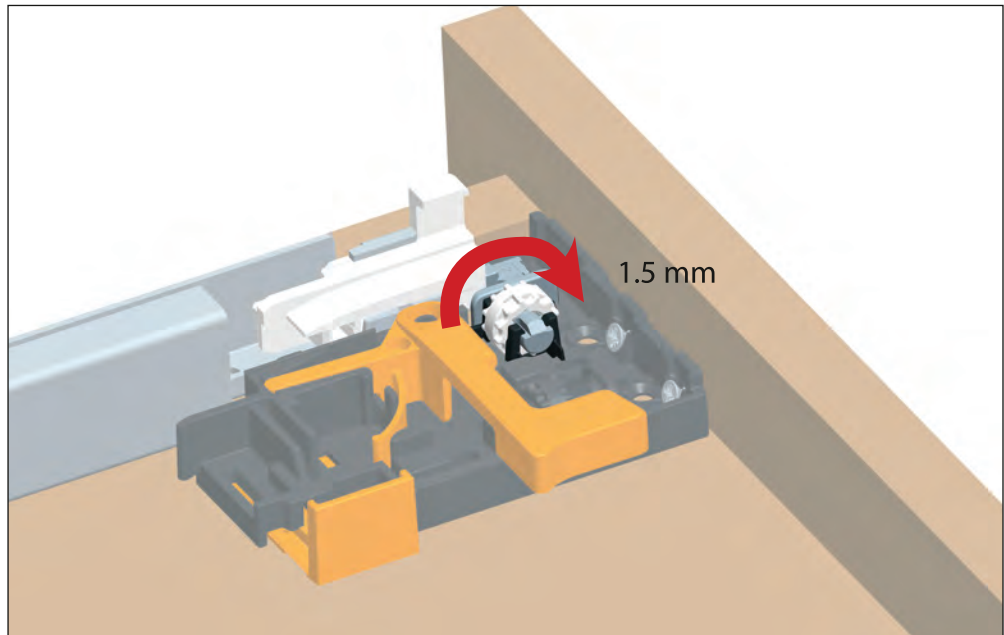
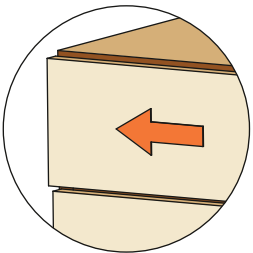
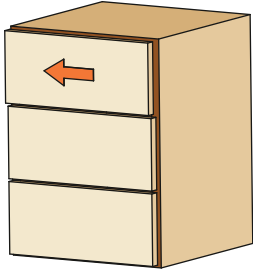

Rotate the white wheel towards the back of the drawer to adjust right.
The clip shows the position 0.

This operation is tool free.

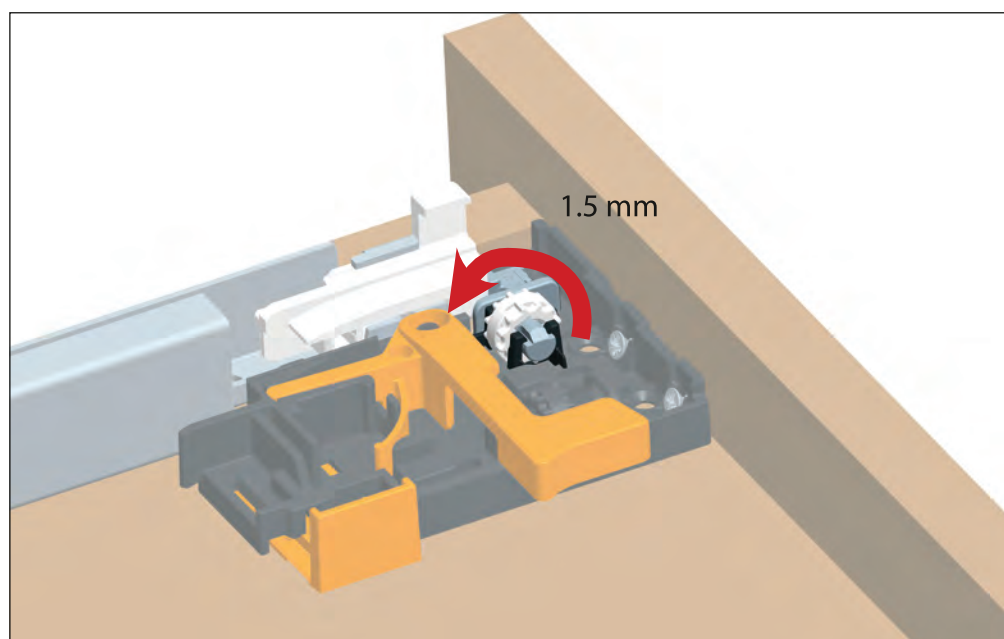
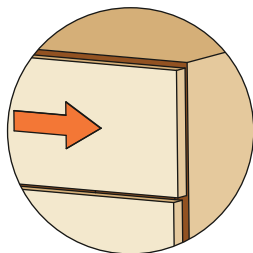
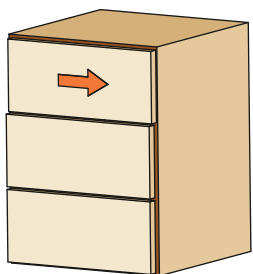

For sideways adjustment, it is recommended that the adjusters on the clips are operated in the same direction, in order to maintain the correct alignment and movement of the runners.

DRAWER SLIDE

อุปกรณ์รางลิ้นชัก



Futura - with 3 way adjustable clip

Depth adjustment + 2 mm - 2 mm

Rotate the black wheel towards the inside of the drawer to move the drawer backward.
The clip shows the position 0.

This operation is tool free.

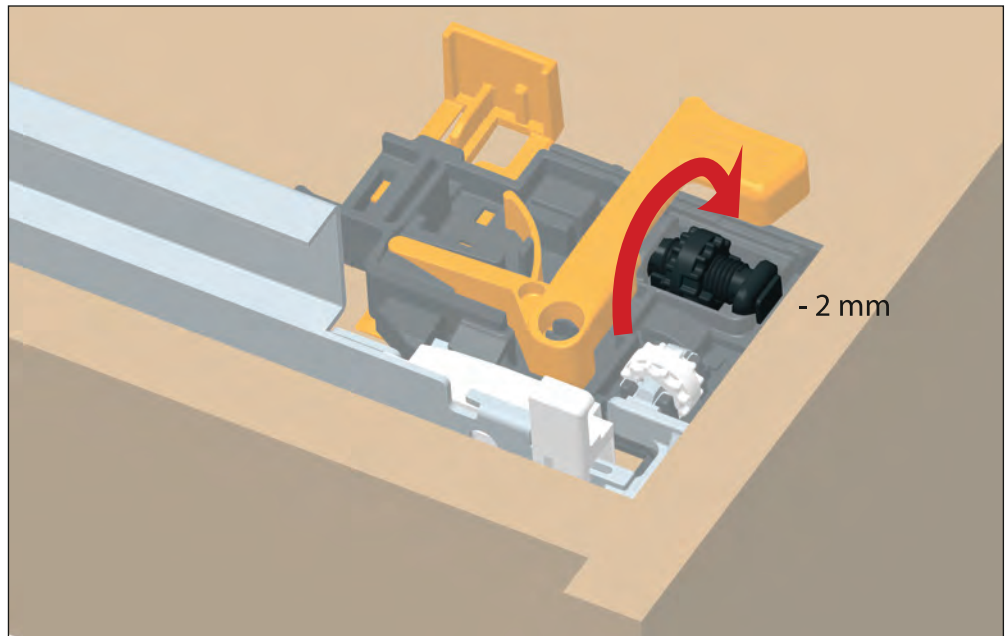
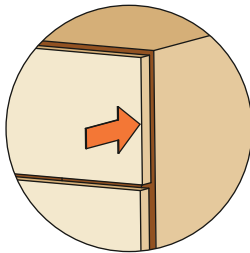
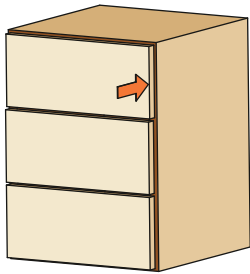

Rotate the black wheel towards the outside of the drawer to move the drawer forward.
The clip shows the position 0.

This operation is tool free.

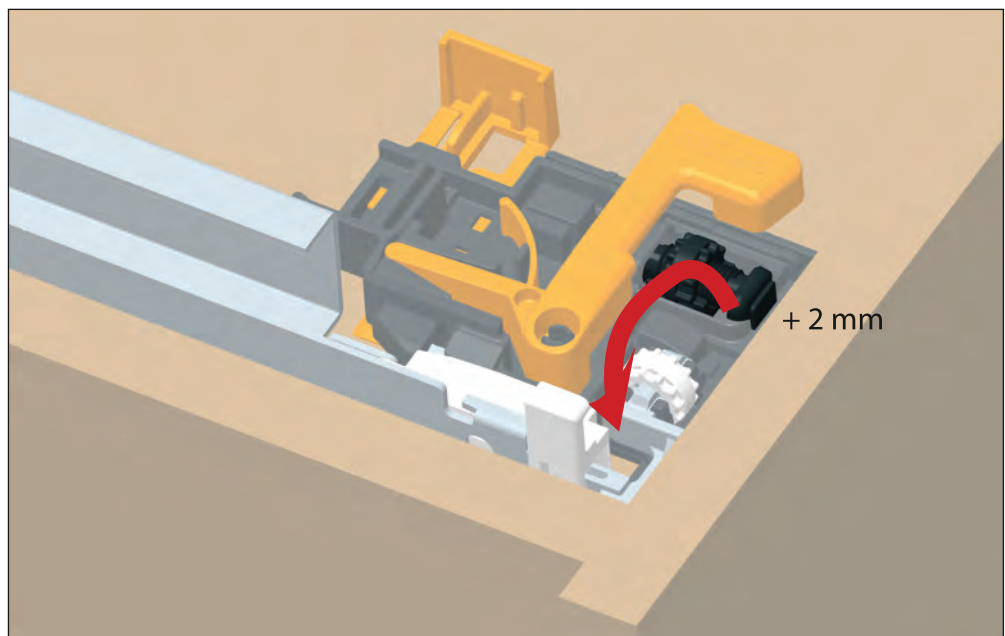
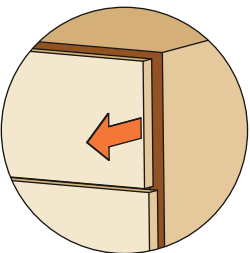
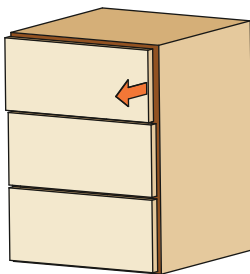

S-200

อุปกรณ์กันแกว่งรางลิ้นชัก Futura Push synchroniser

The synchronisation system for Push-open Futura runners has been developed to ensure that drawers of any width can be opened with minimum effort.

The system links the two runners, which thus become a single element; a pressure at any point of the drawer frontal (even at the extremities), is sufficient for the Push devices to release and consequently for the drawer to self-open.

The synchroniser can be used with any drawer width; its functionality is at its best with wider drawers. It can be used on drawers of any width; however it is recommended for drawers over 80 cm in width.

Product features:

- perfectly silent sliding movement
- the load capacity of the runner remains unchanged
- available on all runner lengths
- min. width of the cabinet (X) = 280 mm
- max. width of the cabinet (X) = 1300 mm
- bar length = 1150 mm (to cut to length)



อุปกรณ์กันแกว่งสำหรับกล่องลิ้นชักขนาดใหญ่ โดยใช้สำหรับกล่องลิ้นชักขนาดกว้าง 900 มม. ขึ้นไป

S-200 Futura Push synchroniser

Technical information

Full-extension

The assembly of the synchroniser requires a minimum 80 mm wide notch in the rear panel.

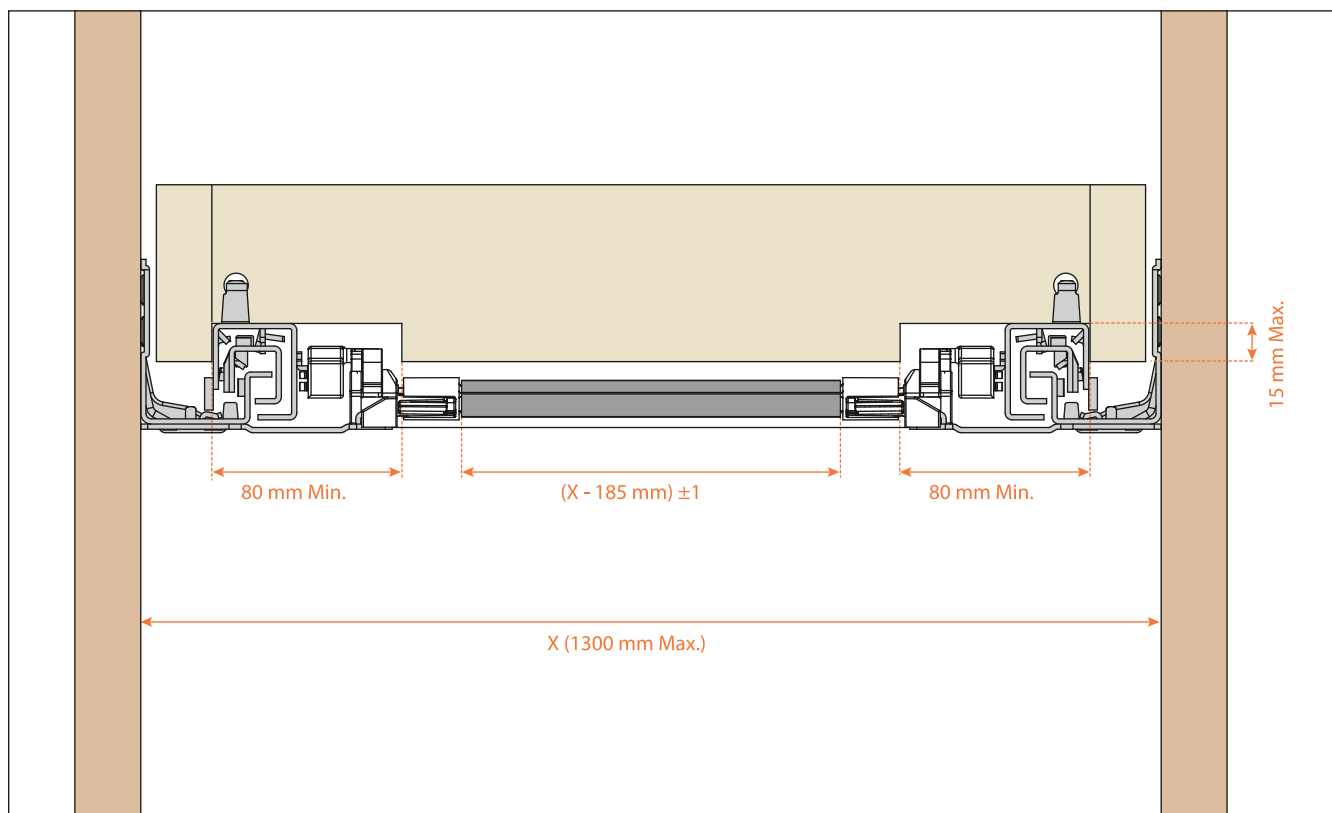

1 KIT:

- 1 stabiliser bar
- 2 end caps
- 2 driver pins
- 1 right carrier plate and 1 left carrier plate



DRAWER SLIDE

อุปกรณ์รางลิ้นชัก



S-100 Stabilizer for drawers

อุปกรณ์กันแกว่งรางลิ้นชัก



- To be fitted on both right and left sides of the drawer
- Cam adjustment to allow a perfect bearing of the wheels to the cabinet sides
- Combined with Push runners it allows the opening also by pressing the extremities of the drawer
- It improves the overall stability of the drawer

- อุปกรณ์กันกล่องลิ้นชักแกว่ง
- ติดตั้งด้านซ้ายและขวาของกล่องลิ้นชัก
- สามารถปรับระดับตามขนาดของแผงข้างข้างตู้
- เพื่องานเปิดที่สมบูรณ์ โดยเฉพาะกับรางลิ้นชักกดกระเดื่อง

Template with assembly instructions
Included in the packing



DRAWER SLIDE

อุปกรณ์รางลิ้นชัก



Lineabox

SALICE



Lineabox - Metal drawer

Lineabox is the metal drawer from Salice, characterised by streamlined and simple lines with minimal side thickness and clean, sophisticated lines.

It is available in 4 different heights in the versions with 2 metal sides and wooden back panel, and in 3 different heights in the versions with 3 metal sides. The 2-sided drawer can have both a visible back or with the edge of the back panel covered by the drawer side (recessed back panel), giving a more streamlined finish to the drawer.

Lineabox can be also used as under-sink drawer and sink waste cut-out drawer, thus meeting every need in kitchens and bathrooms.

The range is completed by the Lineabox 4-sided internal drawer, available with or without insert, which is 8 mm thick and can be made in any material.

Lineabox is very versatile and many distinguishing features makes it a unique and unparalleled drawer.

The slim 9 mm wall thickness makes Lineabox one of the thinnest drawers ever.

Furthermore, the assembly components are inserted inside its structure, so that there are no visible screws. The assembly process is fast and can be carried out without the need for tools, machines or templates.

Lineabox is highly customisable. The back dimensions can be modified according to the width of the cabinet.

The sliding movement is fluid and silent, thanks to Salice Futura runners and, wherever a product is needed with high load-bearing capacity, to the CC70 full-extension runners.



DRAWER SLIDE

อุปกรณ์รางลิ้นชัก



Lineabox - 2-Sided - H 75 mm



Lineabox metal sides, wooden bottom and back panel.
Height of the side 75 mm - Internal height 46 mm.
For use with F70 and Futura full-extension runners.

- Rapid assembly system, with no machinery or templates needed
- Rapid mounting and removal of drawer frontal
- Height, sideways and depth adjustment of the drawer incorporated in the runner fixing clips
- Back and bottom thickness: 16 mm
- Material: Aluminium
- Lineabox sides cut to length
- Sides: 90° cut end
- Finishes: White - Titanium - Champagne - Stainless steel

Setting of the back and the bottom of the drawer

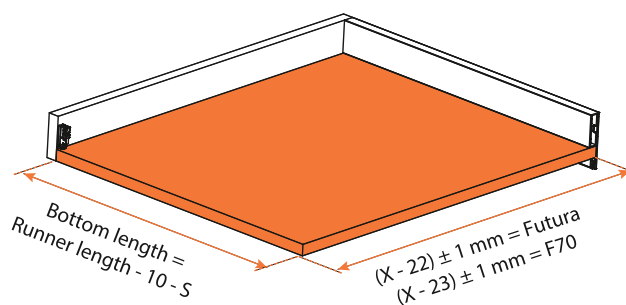
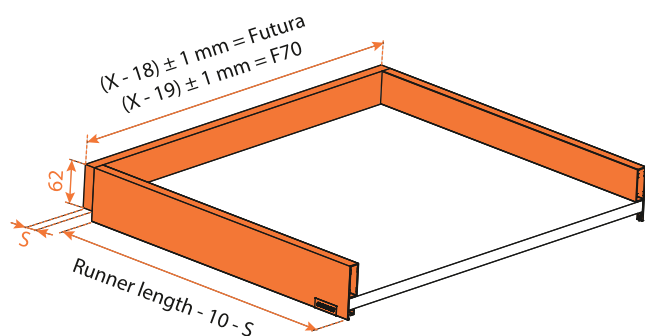

X = Internal width of the cabinet
S = Back thickness

Elements of the drawer

1	C-FF-6 Screw-on frontal and back fixing	4 pcs.
2	C-FF-3 Frontal and back connecting fitting	4 pcs.
3	C-FF-5 Cover cap with embossed logo	2 pcs.

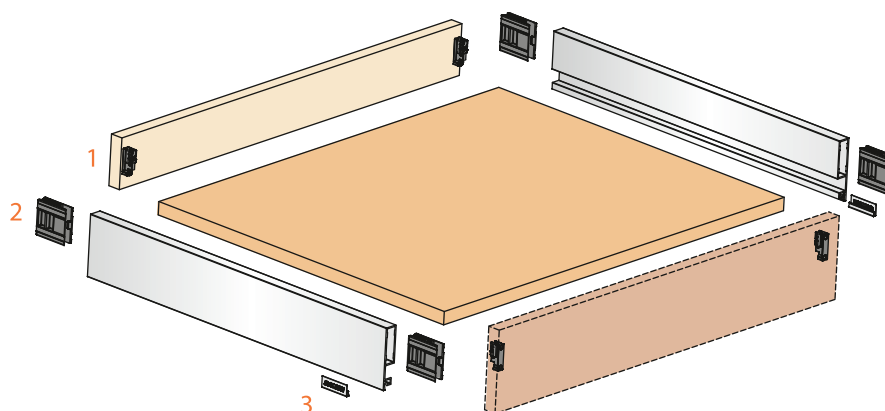

DRAWER SLIDE

อุปกรณ์รางลิ้นชัก



Lineabox - 2-Sided - H 75 mm

Dimensions

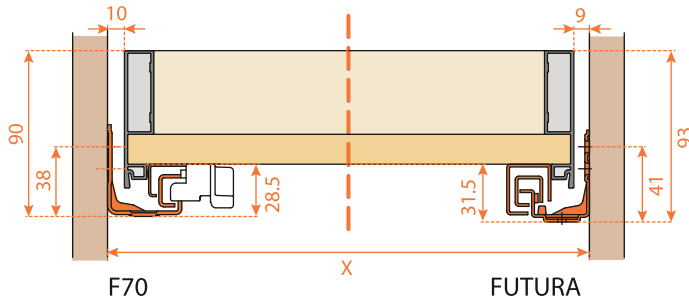

Dimensions of the metal side

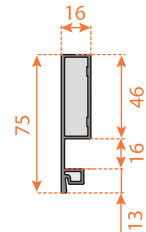

Frontal drilling

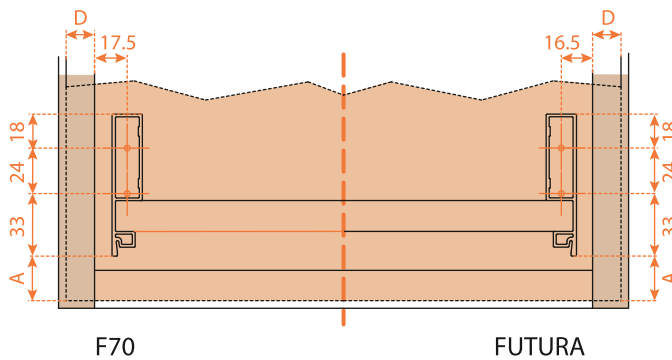

Back drilling

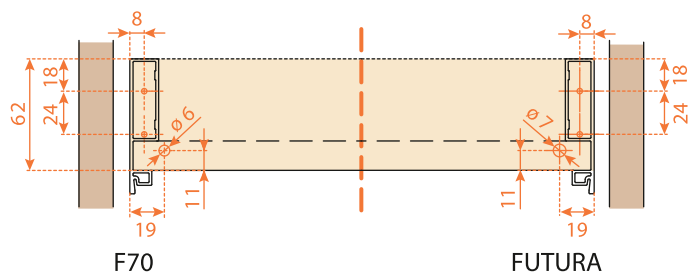

DRAWER SLIDE

อุปกรณ์รางลิ้นชัก



Lineabox - 2-Sided - H 101 mm



Lineabox metal sides, wooden bottom and back panel.
Height of the side 101 mm - Internal height 72 mm.
For use with F70 and Futura full-extension runners.

- Rapid assembly system, with no machinery or templates needed
- Rapid mounting and removal of drawer frontal
- Height, sideways and depth adjustment of the drawer incorporated in the runner fixing clips
- Back and bottom thickness: 16 mm
- Material: Aluminium
- Lineabox sides cut to length
- Sides: 90° cut end
- Finishes: White - Titanium - Champagne - Stainless steel

Setting of the back and the bottom of the drawer

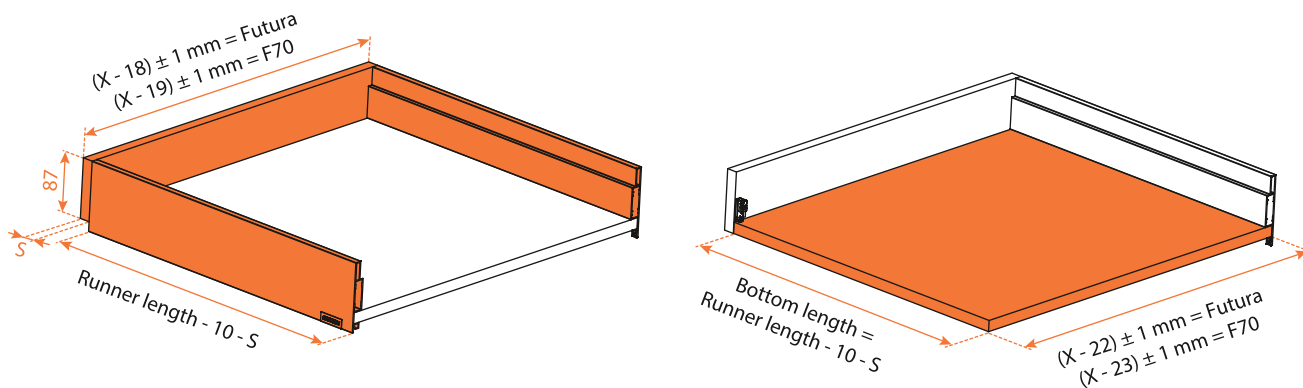

X = Internal width of the cabinet
S = Back thickness

Elements of the drawer

1	C-FF-6 Screw-on frontal and back fixing	4 pcs.
2	C-FF-3 Frontal and back connecting fitting	4 pcs.
3	C-FF-5 Cover cap with embossed logo	2 pcs.

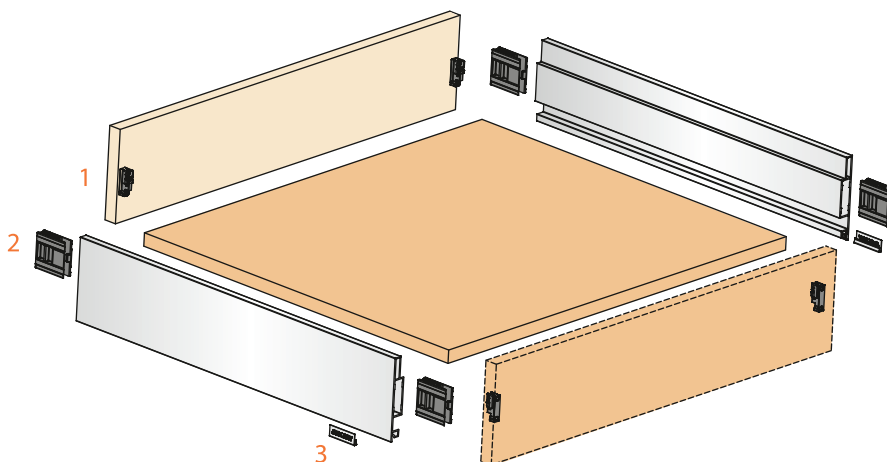

DRAWER SLIDE

อุปกรณ์รางลิ้นชัก



Lineabox - 2-Sided - H 101 mm

Dimensions

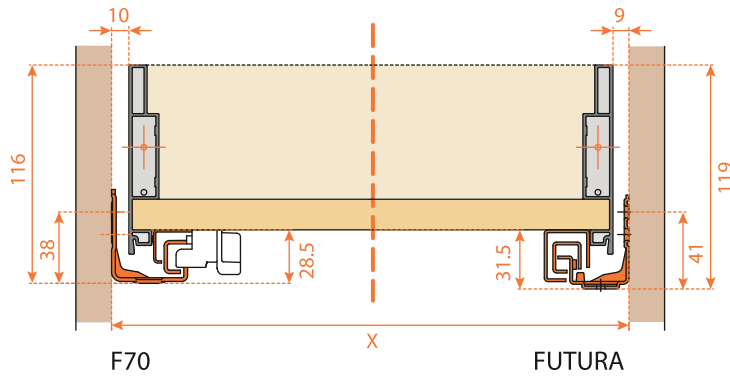

Dimensions of the metal side

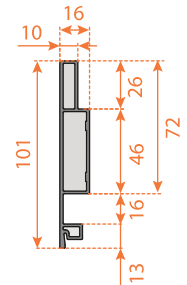

Frontal drilling

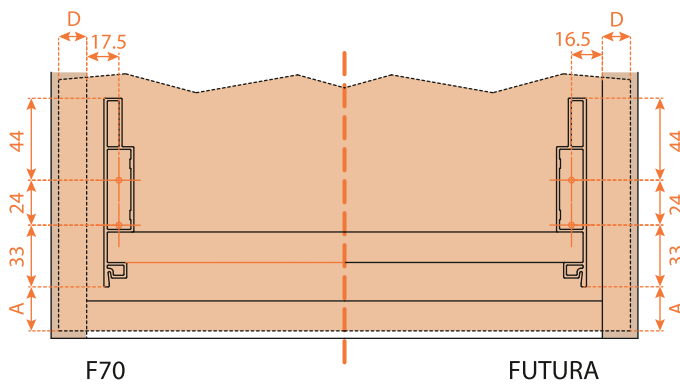

Back drilling

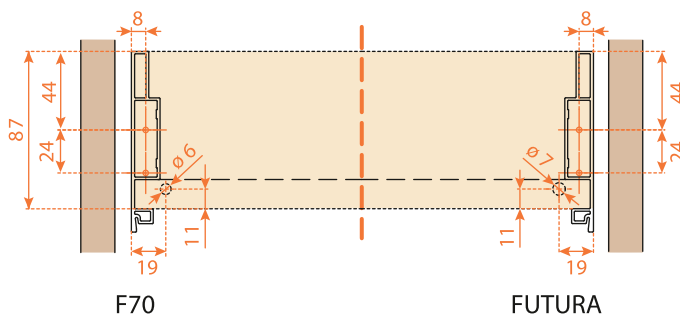

DRAWER SLIDE

อุปกรณ์รางลิ้นชัก



Lineabox - 2-Sided - H 178 mm



Lineabox metal sides, wooden bottom and back panel.
Height of the side 178 mm - Internal height 149 mm.
For use with F70 and Futura full-extension runners.

- Rapid assembly system, with no machinery or templates needed
- Rapid mounting and removal of drawer frontal
- Height, sideways and depth adjustment of the drawer incorporated in the runner fixing clips
- Back and bottom thickness: 16 mm
- Material: Aluminium
- Lineabox sides cut to length
- Sides: 90° cut end
- Finishes: White - Titanium - Champagne - Stainless steel

Setting of the back and the bottom of the drawer

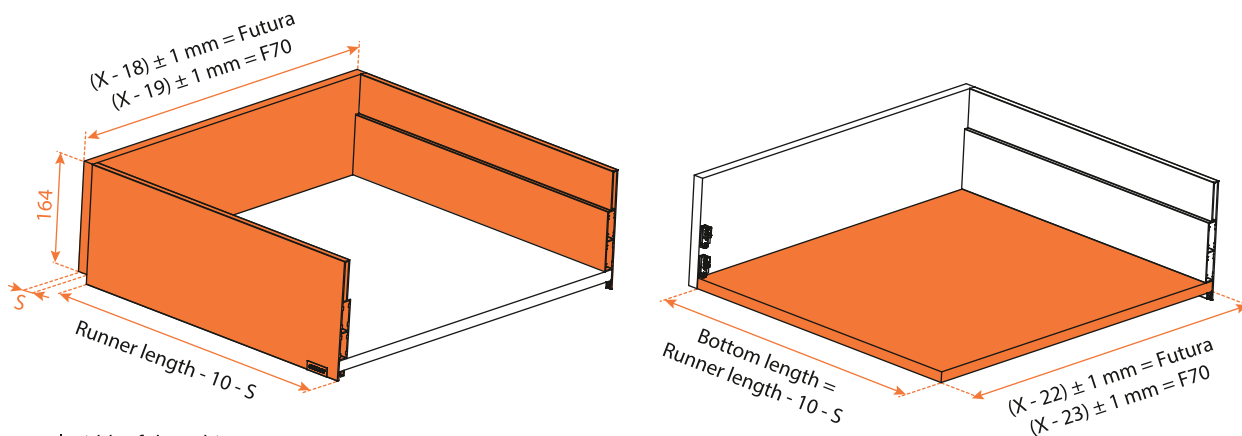

X = Internal width of the cabinet
S = Back thickness

Elements of the drawer

1	C-FF-6 Screw-on frontal and back fixing	8 pcs.
2	C-FF-3 Frontal and back connecting fitting	8 pcs.
3	C-FF-5 Cover cap with embossed logo	2 pcs.

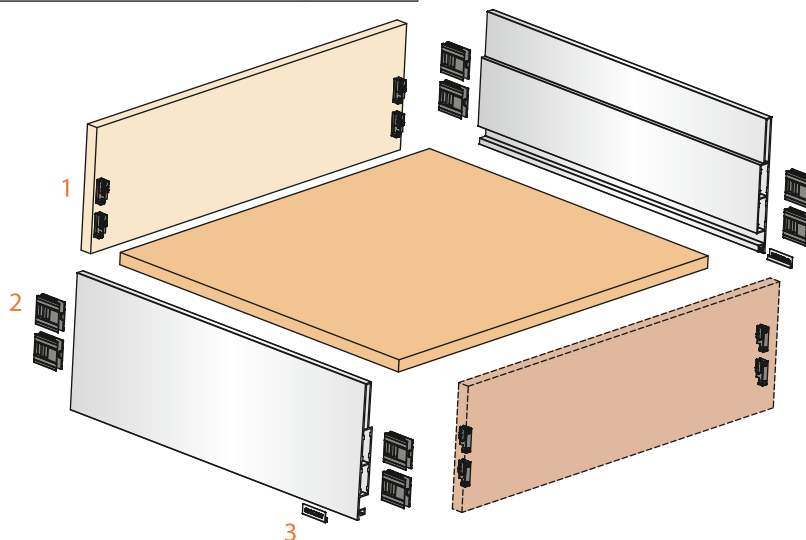

DRAWER SLIDE

อุปกรณ์รางลิ้นชัก



Lineabox - 2-Sided - H 178 mm

Dimensions

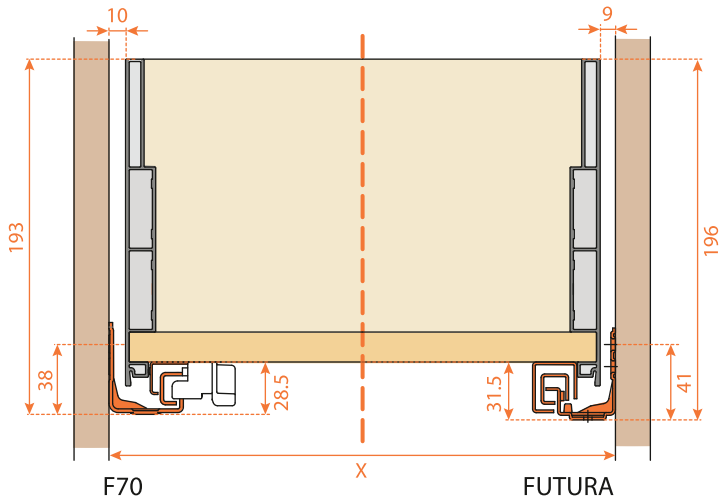

Dimensions of the metal side

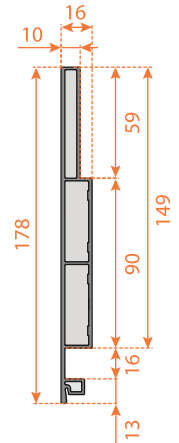

Frontal drilling

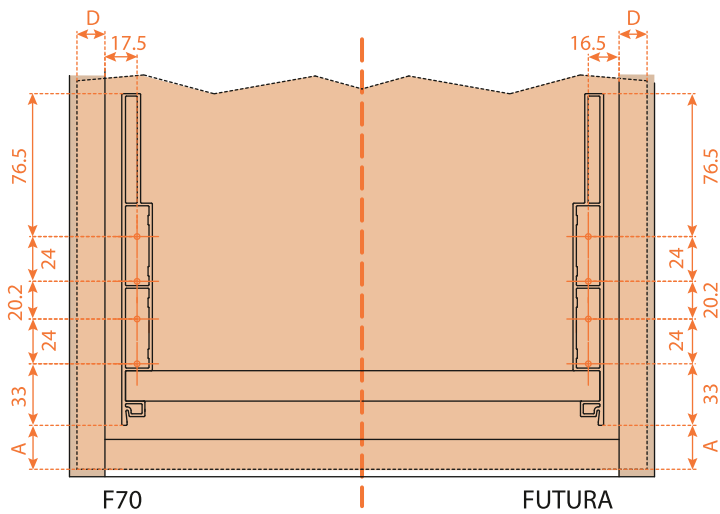

Back drilling

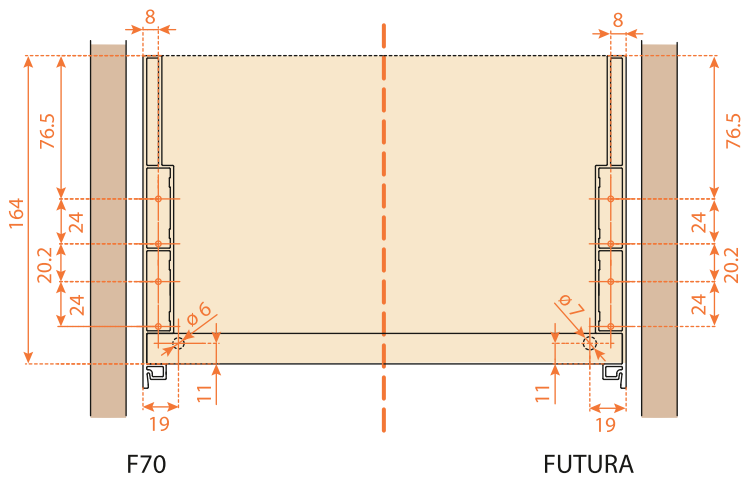

DRAWER SLIDE

อุปกรณ์รางลิ้นชัก



Lineabox - 2-Sided - H 237 mm



Lineabox metal sides, wooden bottom and back panel.
Height of the side 237 mm - Internal height 208 mm.
For use with F70 and Futura full-extension runners.

- Rapid assembly system, with no machinery or templates needed
- Rapid mounting and removal of drawer frontal
- Height, sideways and depth adjustment of the drawer incorporated in the runner fixing clips
- Back and bottom thickness: 16 mm
- Material: Aluminium
- Lineabox sides cut to length
- Sides: 90° cut end
- Finishes: White - Titanium - Champagne - Stainless steel

Setting of the back and the bottom of the drawer

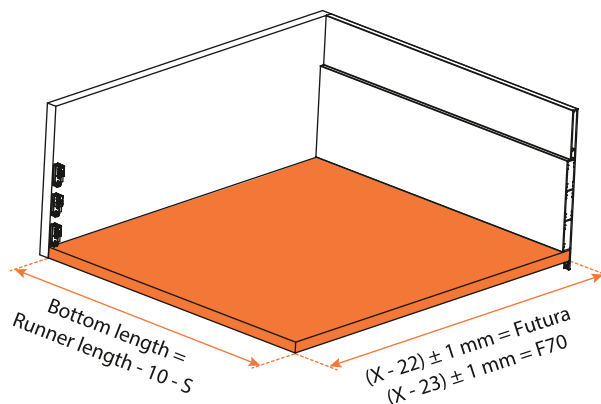
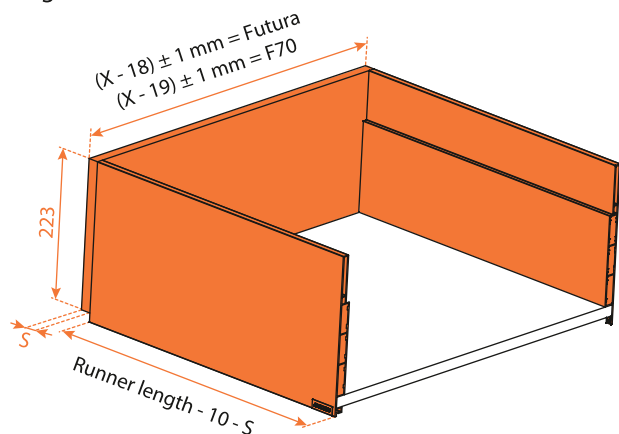

X = Internal width of the cabinet
S = Back thickness

Elements of the drawer

1	C-FF-6 Screw-on frontal and back fixing	12 pcs.
2	C-FF-3 Frontal and back connecting fitting	12 pcs.
3	C-FF-5 Cover cap with embossed logo	2 pcs.

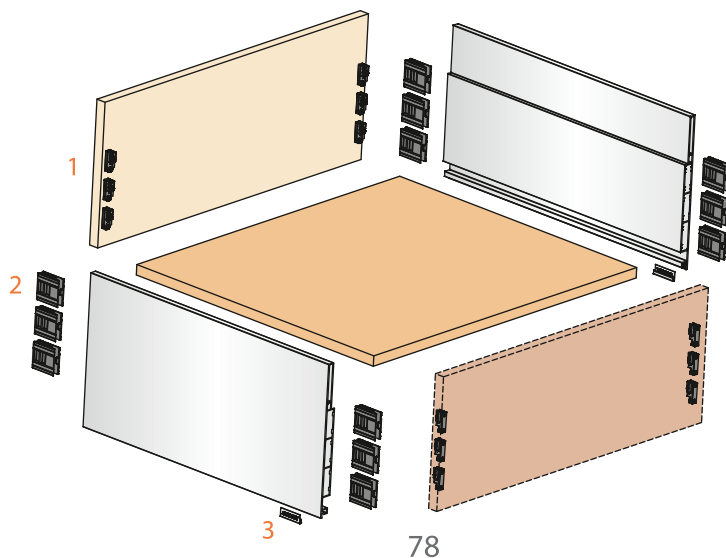

DRAWER SLIDE

อุปกรณ์รางลิ้นชัก



Lineabox - 2-Sided - H 237 mm

Dimensions

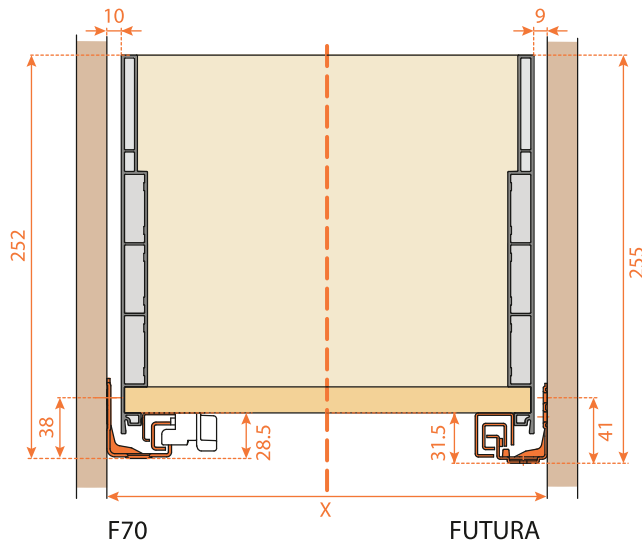

Dimensions of the metal side

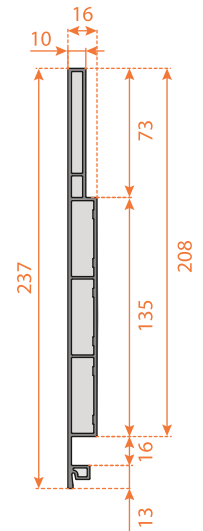

Frontal drilling

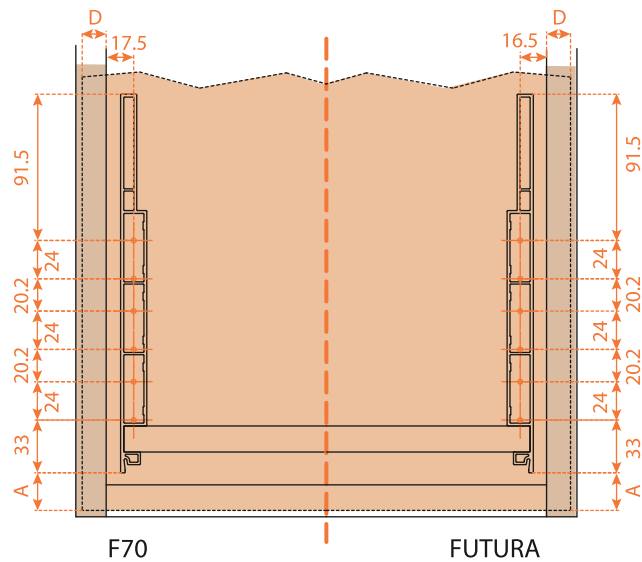

Back drilling

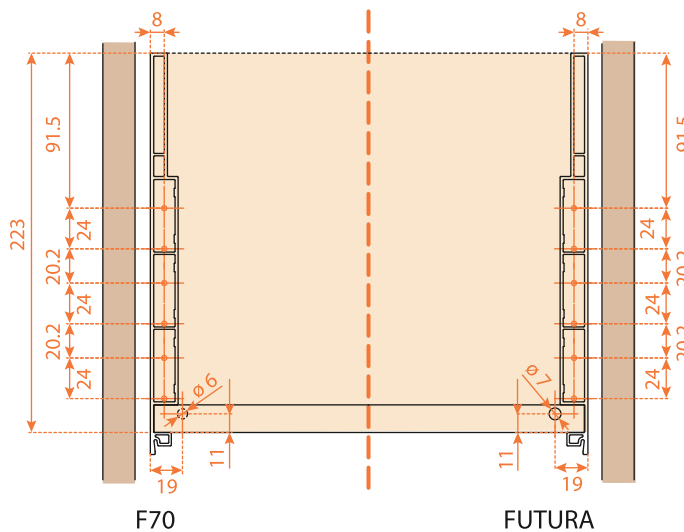

DRAWER SLIDE

อุปกรณ์รางลิ้นชัก



Lineabox - 4-Sided
Internal drawer

DRAWER SLIDE

อุปกรณ์รางลิ้นชัก



Lineabox - 4-Sided - Internal drawer - H 75 mm



Height of Lineabox side 75 mm.
Max. height of front panel 100 mm.
For use with F70 and Futura full-extension runners.

- Rapid assembly system, with no machinery or templates needed
- Rapid mounting and removal of front panel
- Can be modified according to the width of the cabinet
- Height, sideways and depth adjustment of the drawer incorporated in the runner fixing clips
- Material: - aluminum for Lineabox sides and front panel
 - plastic for front panel adapters
 - metal for covers
- Finishes: White - Titanium - Stainless steel

Assembly details

Cut the front panel to length

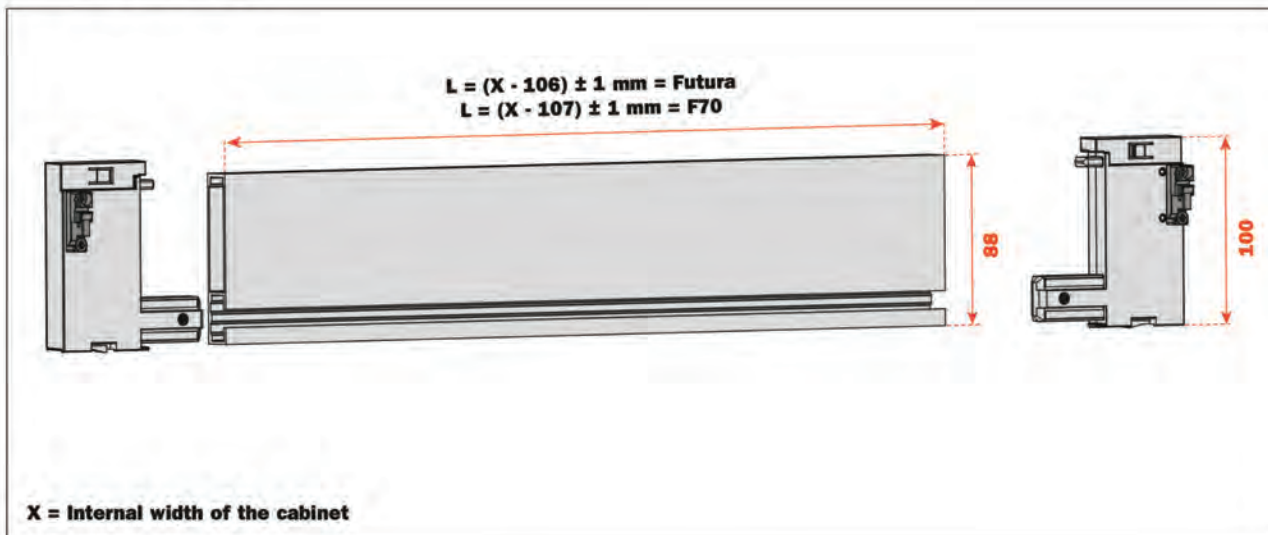

Insert the front panel adapters into the front panel and tighten the locking screws.
Frontal fixings are already premounted.

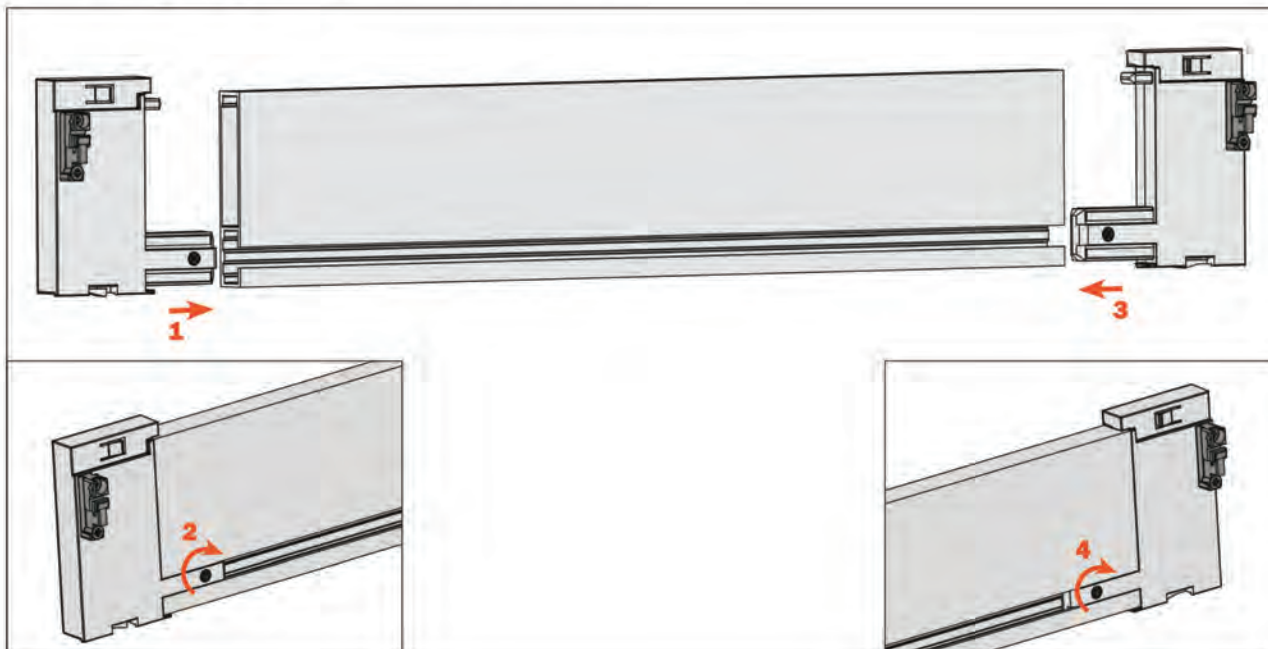

DRAWER SLIDE

อุปกรณ์รางลิ้นชัก

Fix the front panel to the drawer

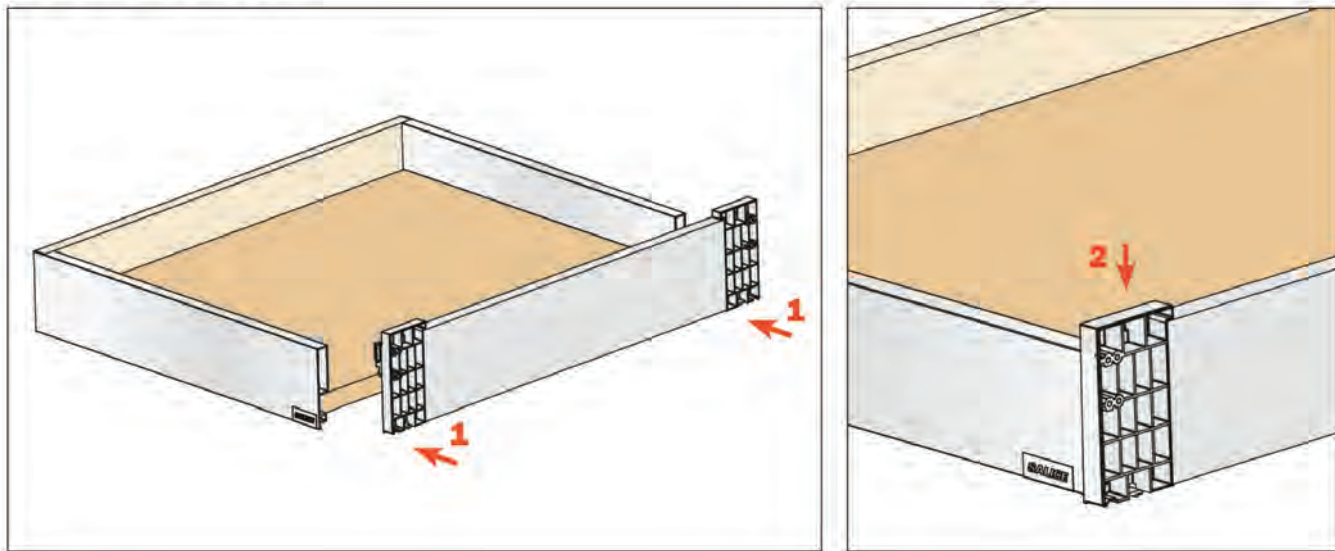

Fix the covers

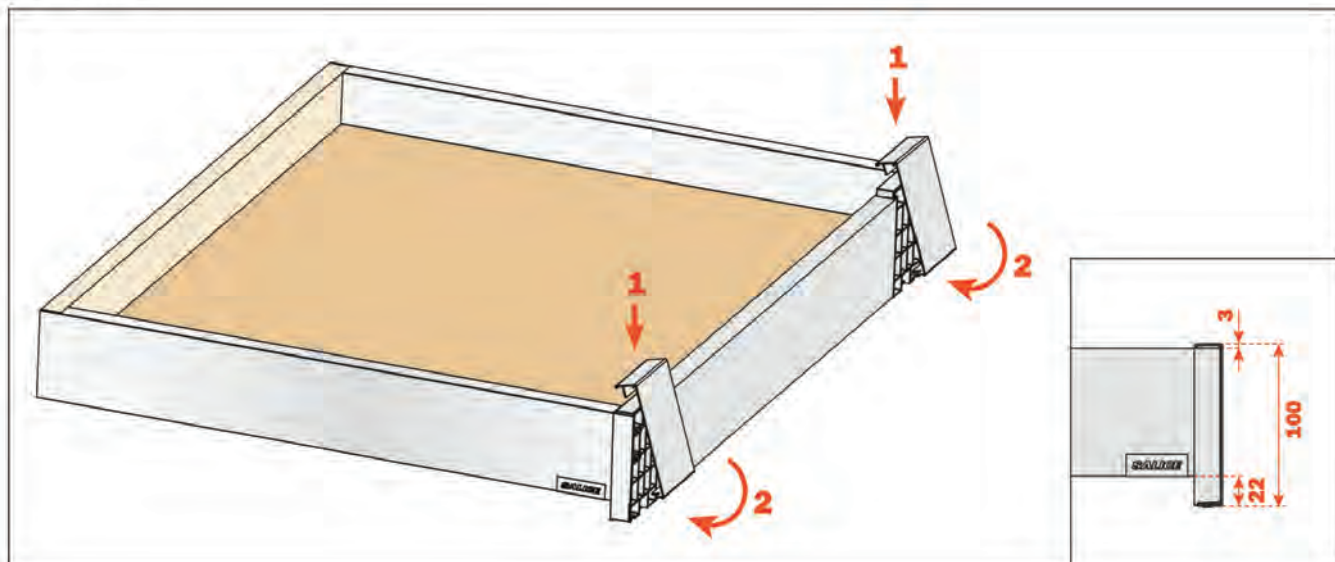

To correct any possible cutting errors of the panel, loosen and retighten the indicated screws

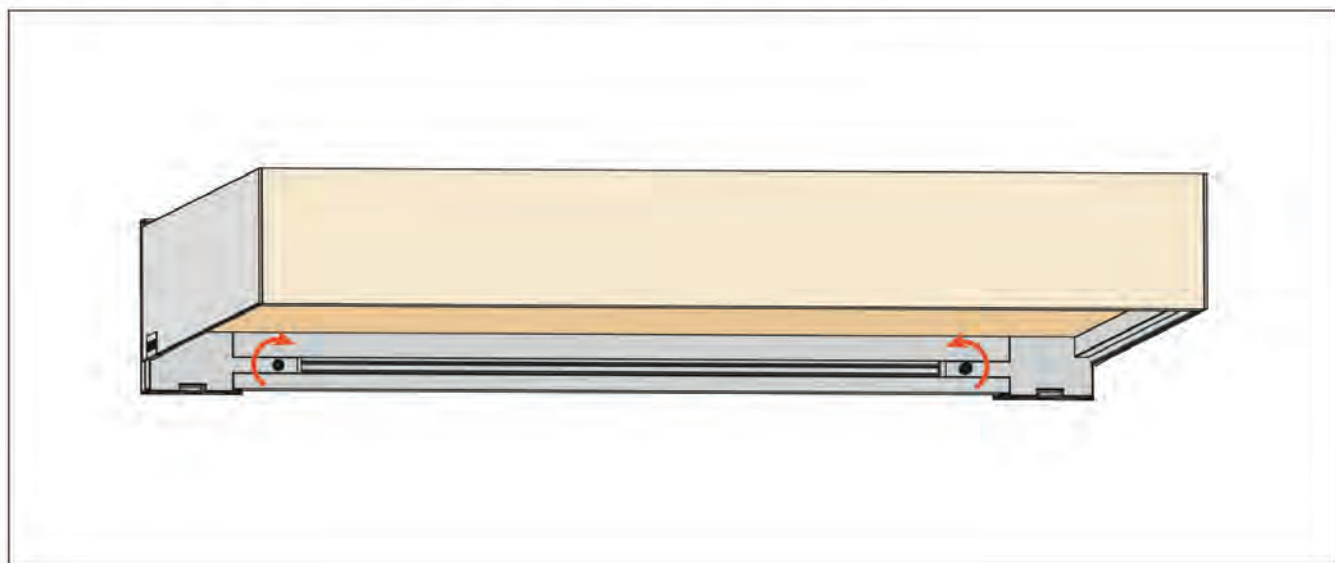

DRAWER SLIDE

อุปกรณ์รางลิ้นชัก



Lineabox - 4-Sided - Internal drawer - H 101 mm



Height of Lineabox side 101 mm.
Max. height of front panel 126 mm.
For use with F70 and Futura full-extension runners.

- Rapid assembly system, with no machinery or templates needed
- Rapid mounting and removal of front panel
- Can be modified according to the width of the cabinet
- Height, sideways and depth adjustment of the drawer incorporated in the runner fixing clips
- Material: - aluminum for Lineabox sides and front panel
 - plastic for front panel adapters
 - metal for covers
- Finishes: White - Titanium - Stainless steel

Assembly details

Cut the front panel to length

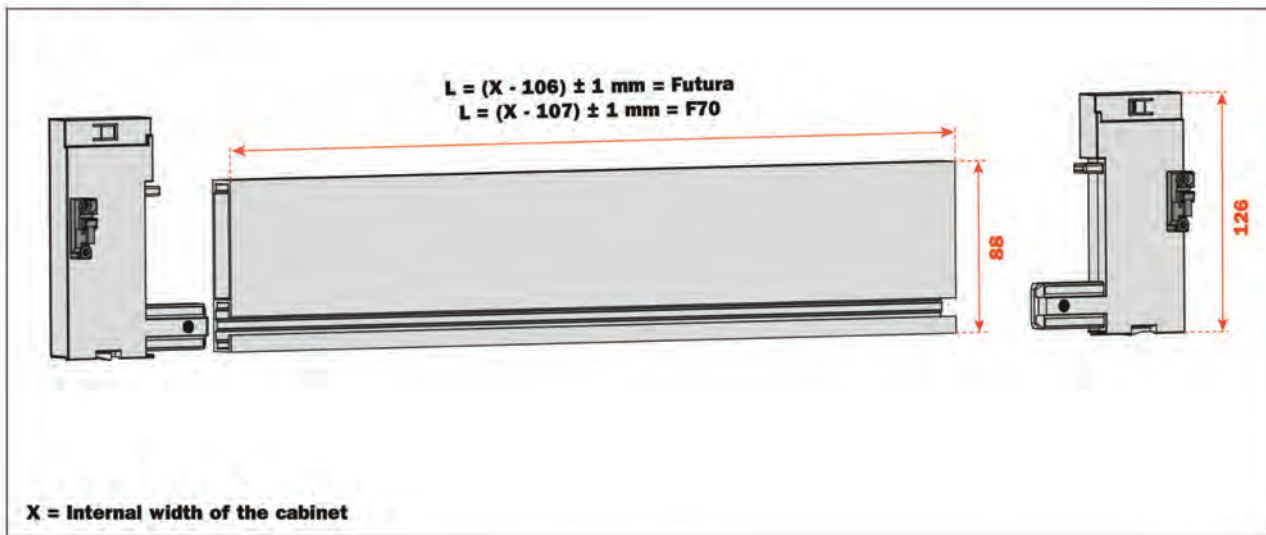

Insert the front panel adapters into the front panel and tighten the locking screws.
Frontal fixings are already premounted.

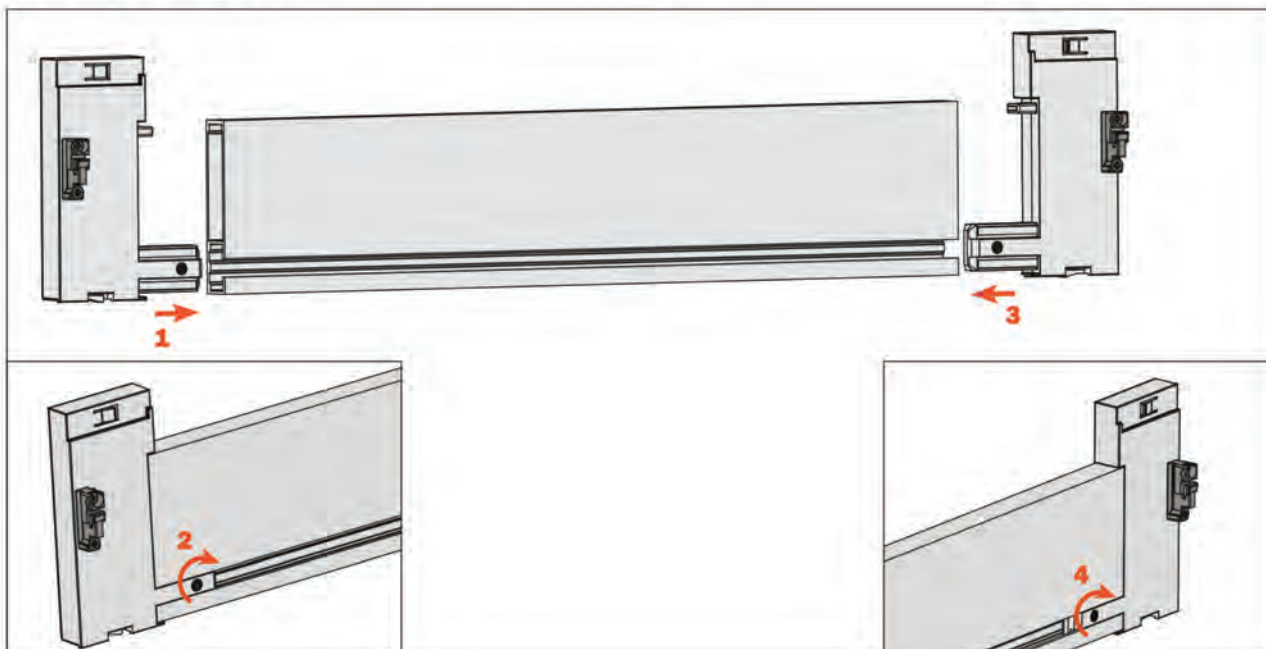

DRAWER SLIDE

อุปกรณ์รางลิ้นชัก



Fix the front panel to the drawer

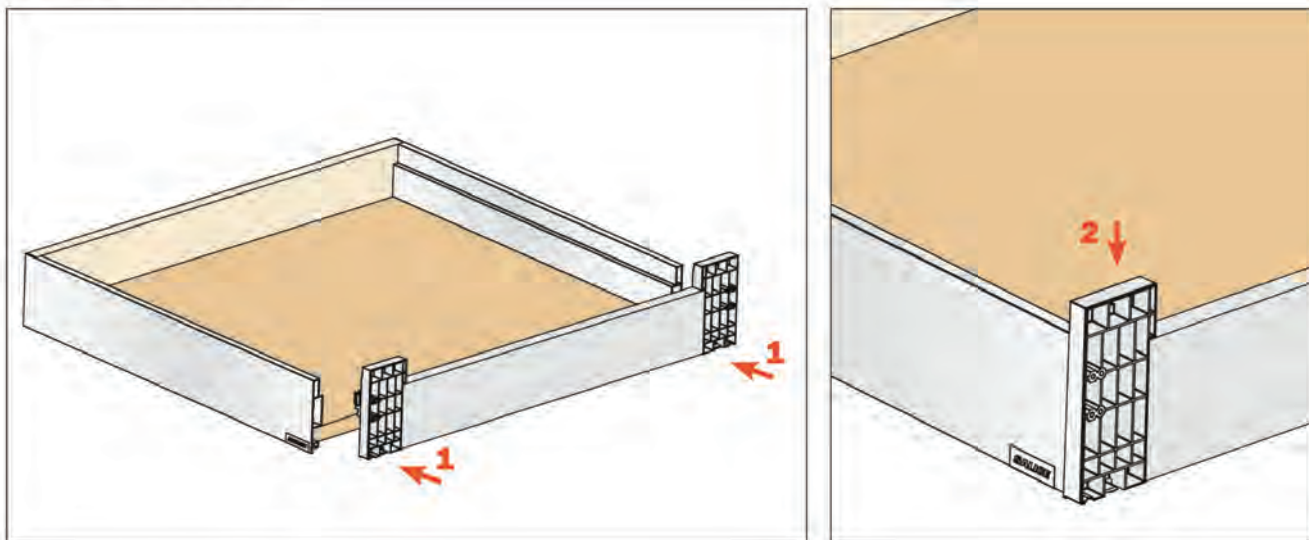

Fix the covers

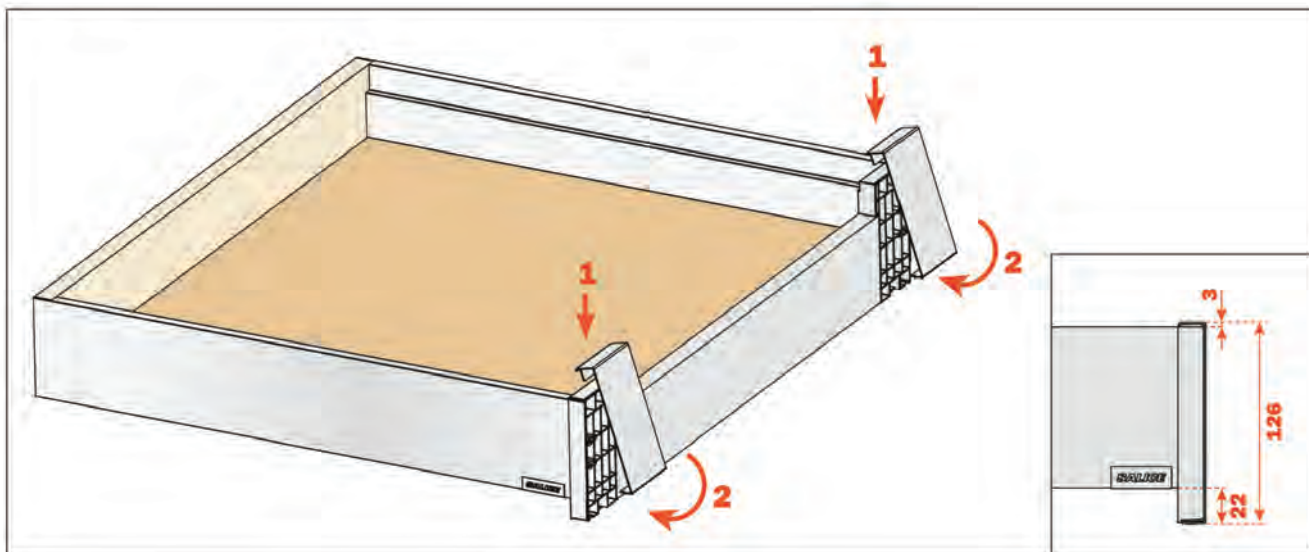

To correct any possible cutting errors of the panel, loosen and retighten the indicated screws

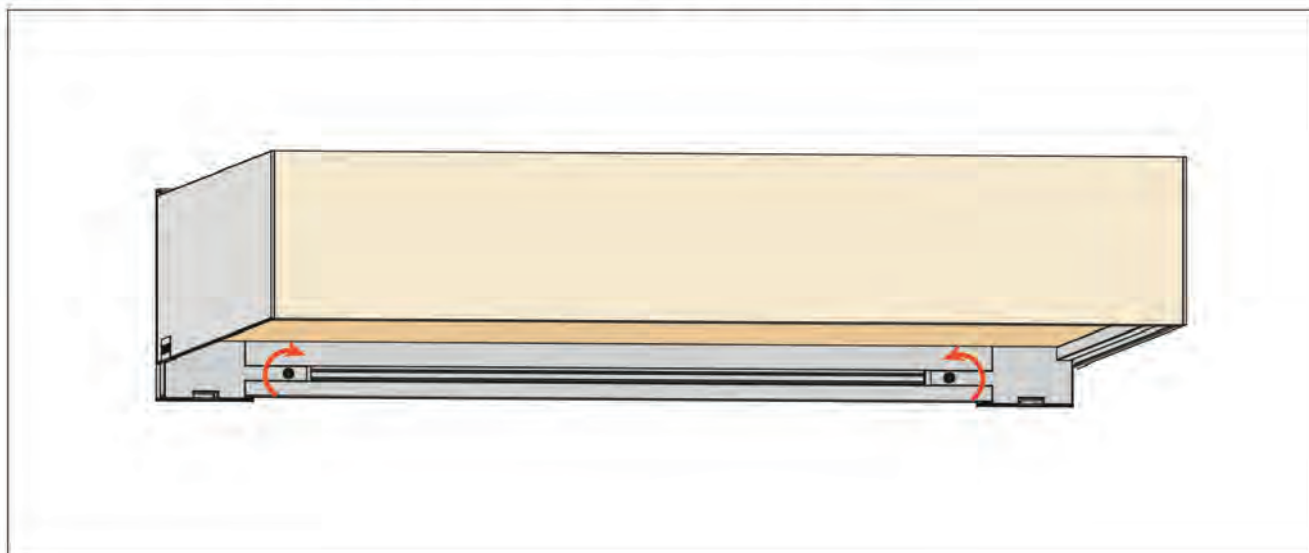

DRAWER SLIDE

อุปกรณ์รางลิ้นชัก



Lineabox - 4-Sided - Internal drawer - H 178 mm



Height of Lineabox side 178 mm.
Max. height of front panel 203 mm.
For use with F70 and Futura full-extension runners.

- Rapid assembly system, with no machinery or templates needed
- Rapid mounting and removal of front panel
- Can be modified according to the width of the cabinet
- Height, sideways and depth adjustment of the drawer incorporated in the runner fixing clips
- Material: - aluminum for Lineabox sides, front panel and railing
 - plastic for front panel adapters
 - metal for covers
- Finishes: White - Titanium - Stainless steel

Assembly details

Cut the front panel and the railing to length

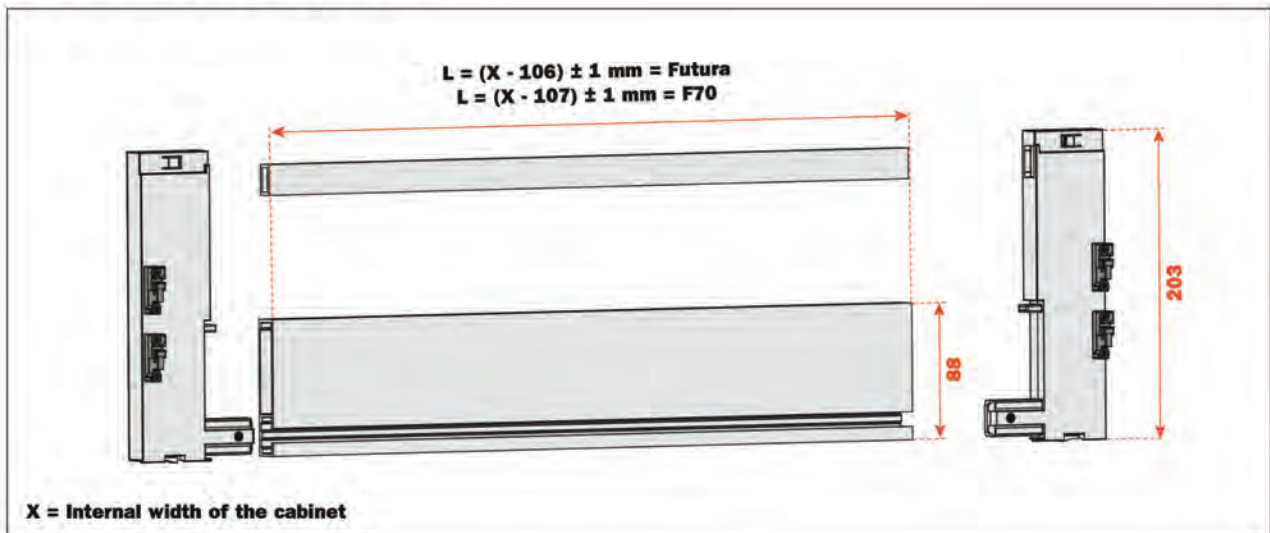

Insert the front panel adapters into the front panel and the railing and tighten the locking screws.
Frontal fixings are already premounted.

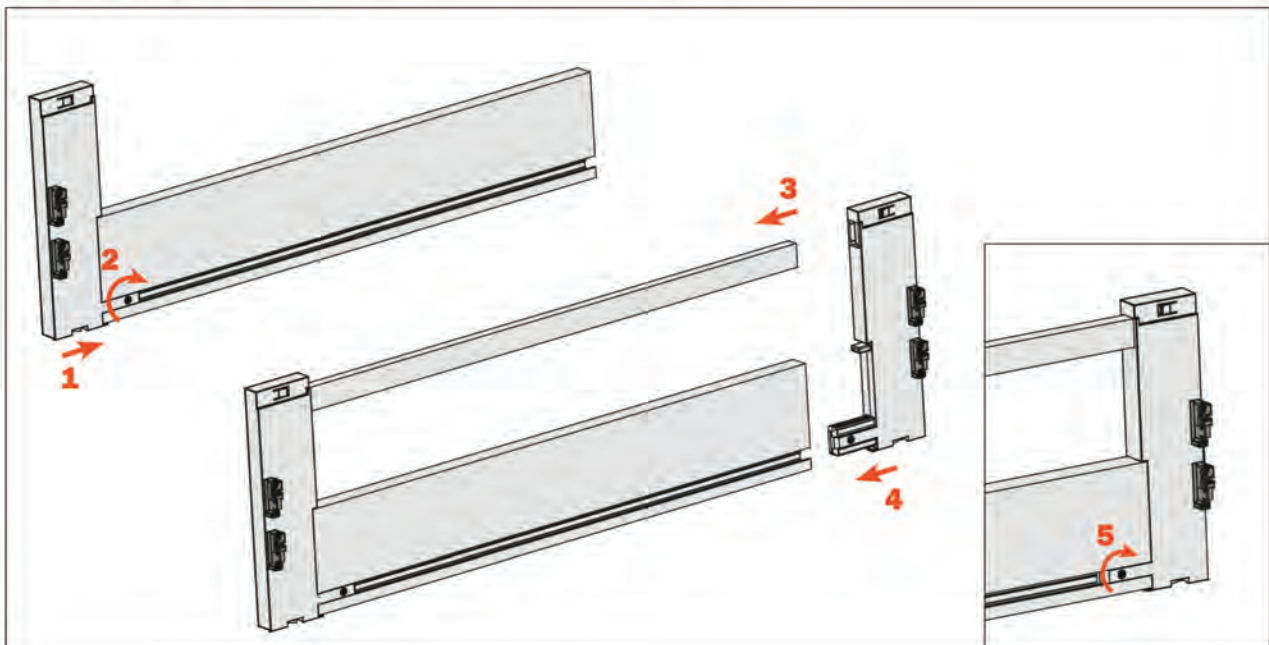

DRAWER SLIDE

อุปกรณ์รางลิ้นชัก

Fix the front panel to the drawer

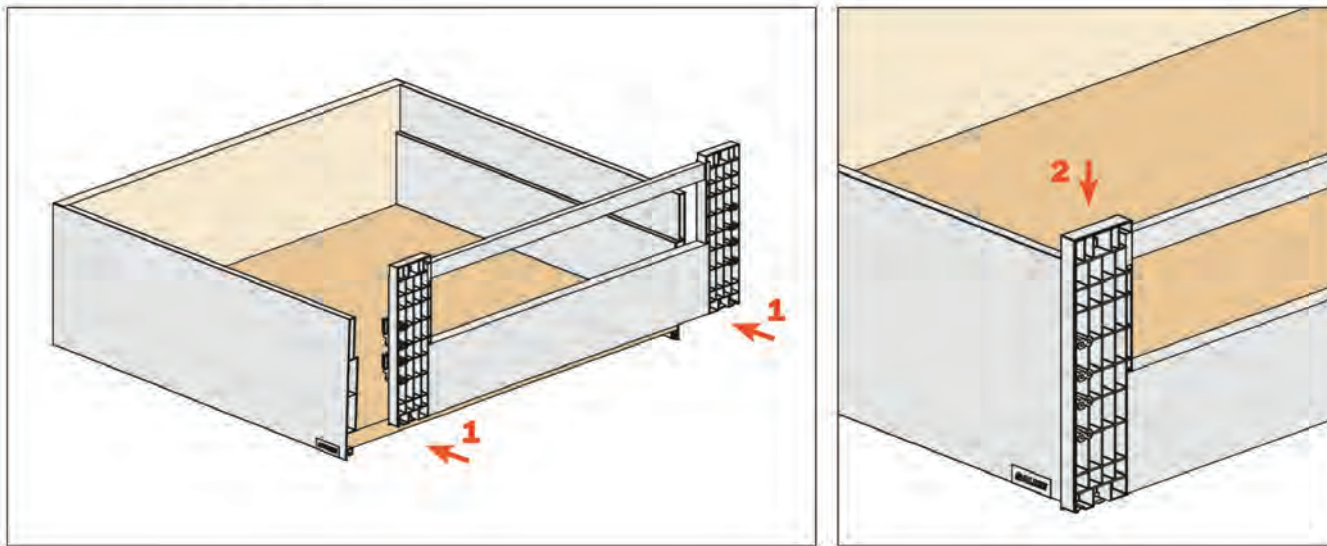

Fix the covers

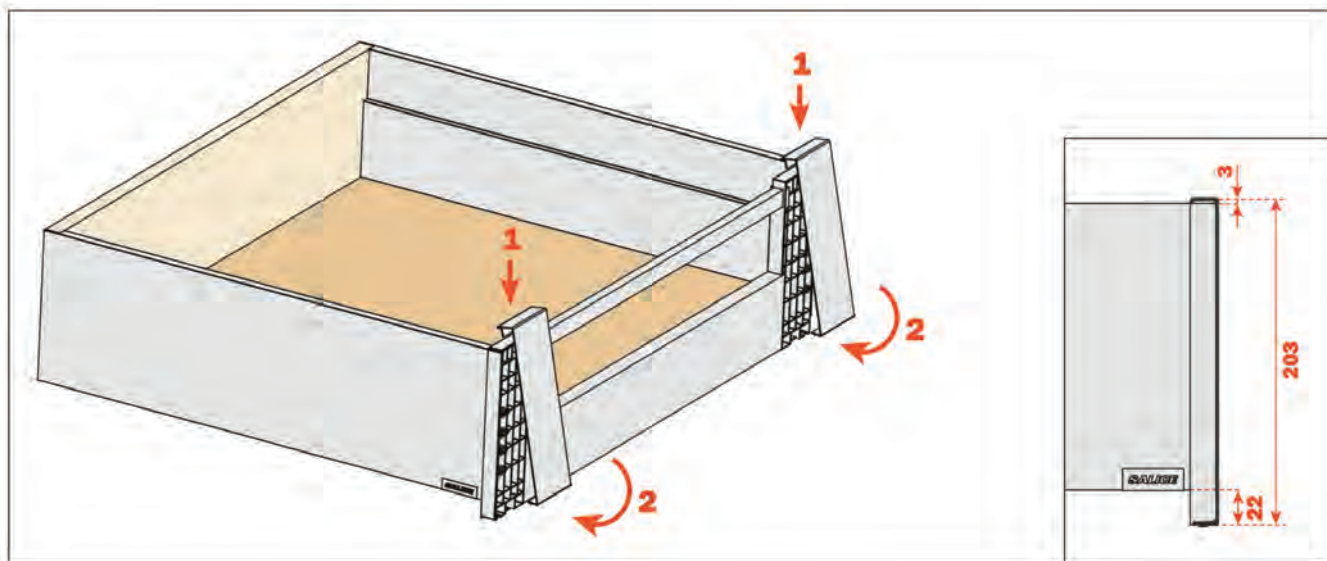

To correct any possible cutting errors of the panel, loosen and retighten the indicated screws.

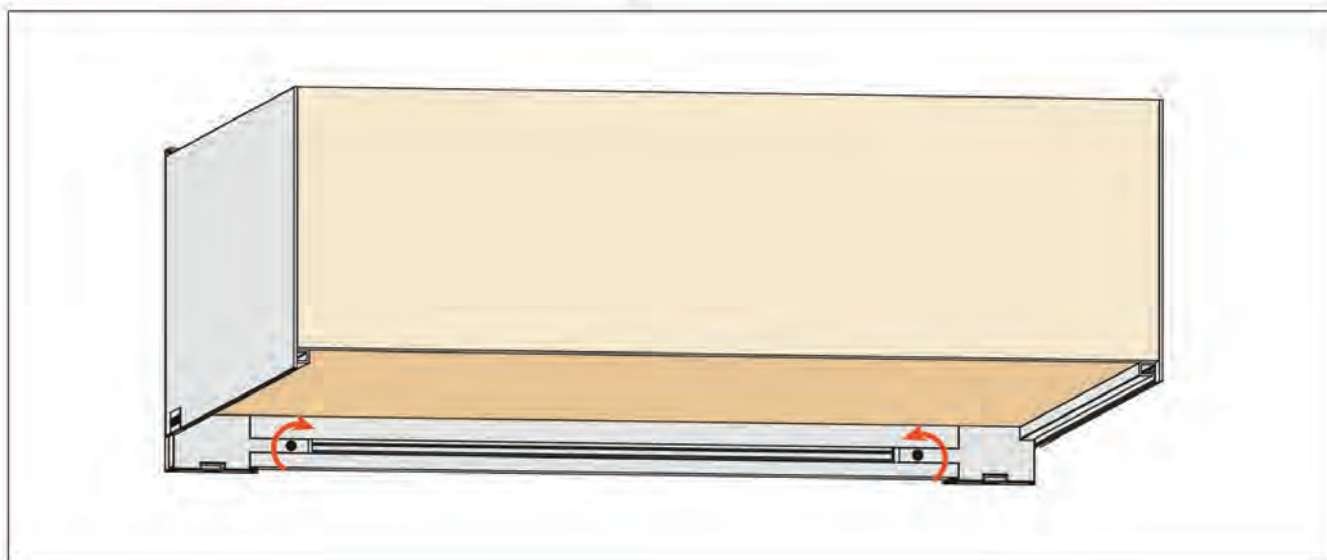

Lineabox - Accessories

C-FF-5

Cover cap with embossed logo



Cover cap with silk-screen printed logo



C-FF-4

Reinforcing supports for the bottom of the drawer



C-FF-1

Template for Frontal and back connecting fitting

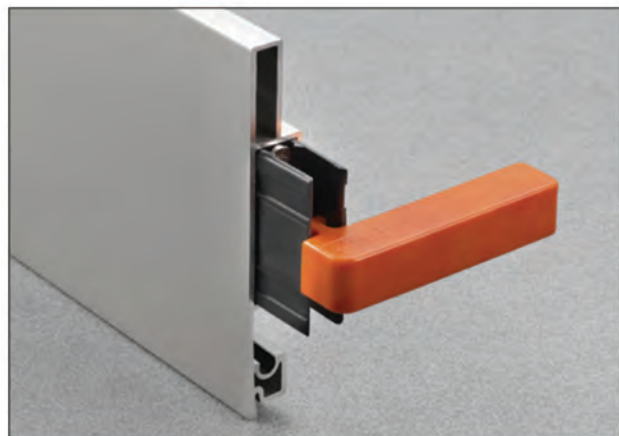

DRAWER SLIDE

อุปกรณ์รางลิ้นชัก



Finishes

White

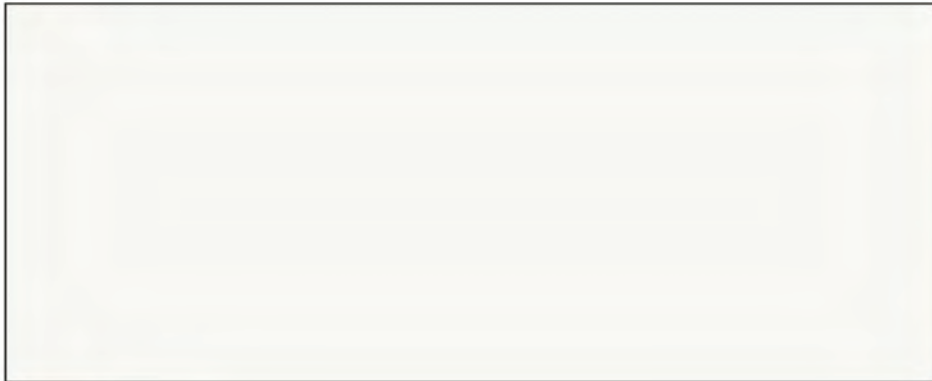

Titanium



Champagne



Stainless steel

