

# HINGE SYSTEM

บานพับ



## UNIVERSAL HINGES

Universal hinges - 110° opening - Standard application  
Hinge with integrated soft-close

- ✓ GLASS DOORS
- ✓ NO DRILLING OF THE GLASS IS REQUIRED
- ✓ 110° OPENING
- ✓ SNAP-ON FIXING WITH DOMI MOUNTING PLATES, SCREW FIXING WITH TRADITIONAL ONES

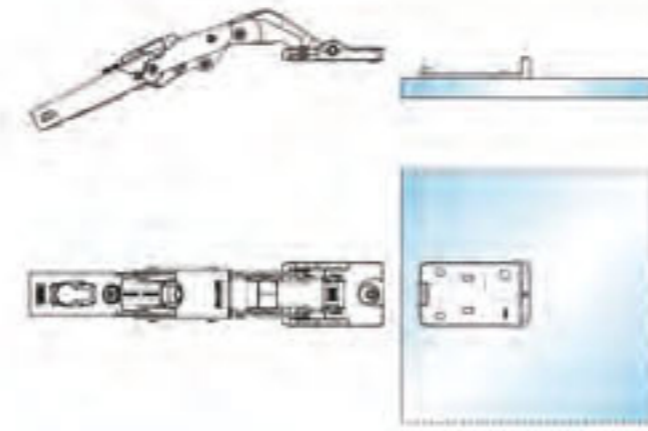
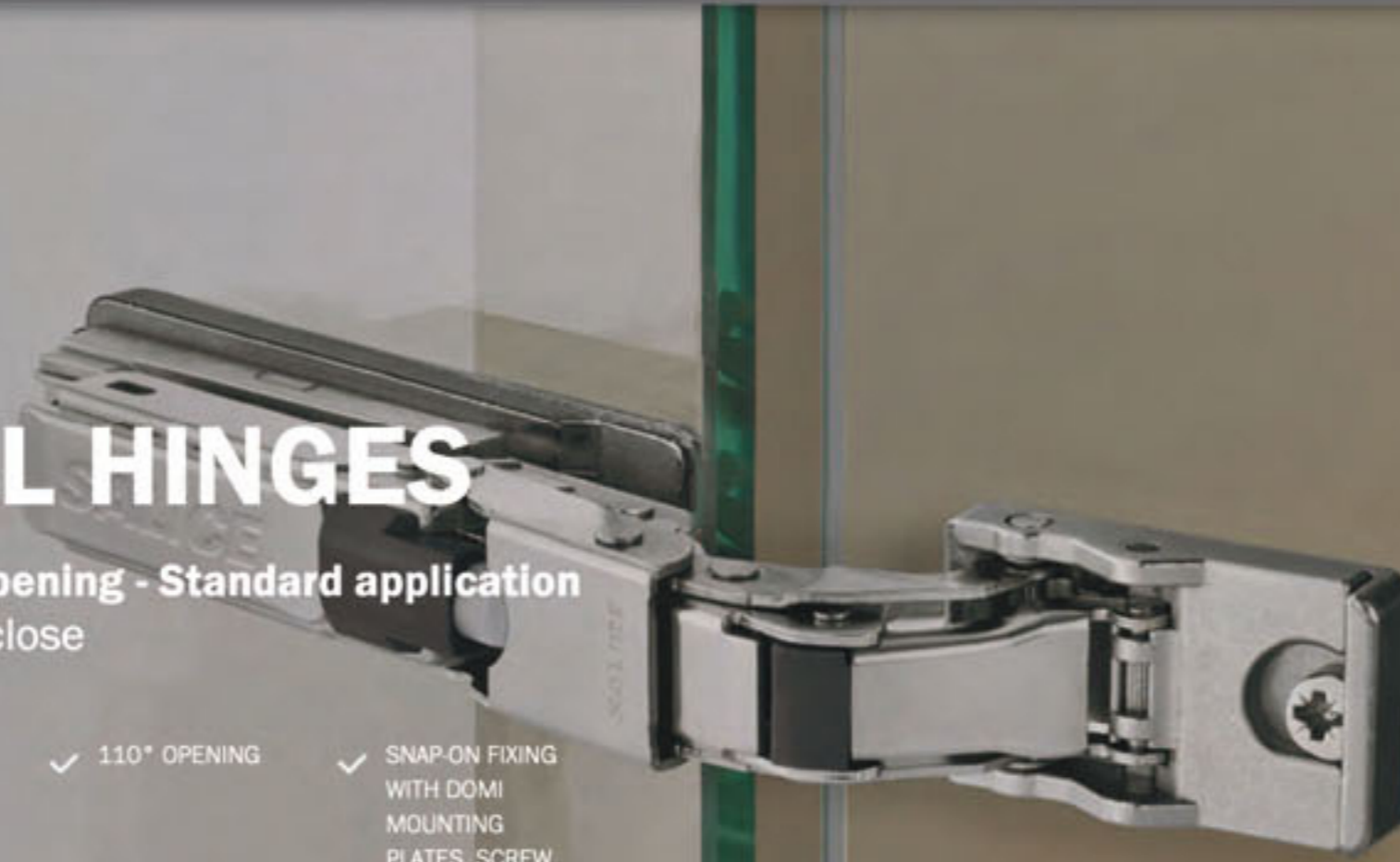

**1)** The hinge plate must be attached to the glass door with a specific adhesive using the correct procedure. We recommend that this operation is carried out by a specialist company. For further information on adhesives and their application, please contact the adhesive manufacturer or your glass supplier.

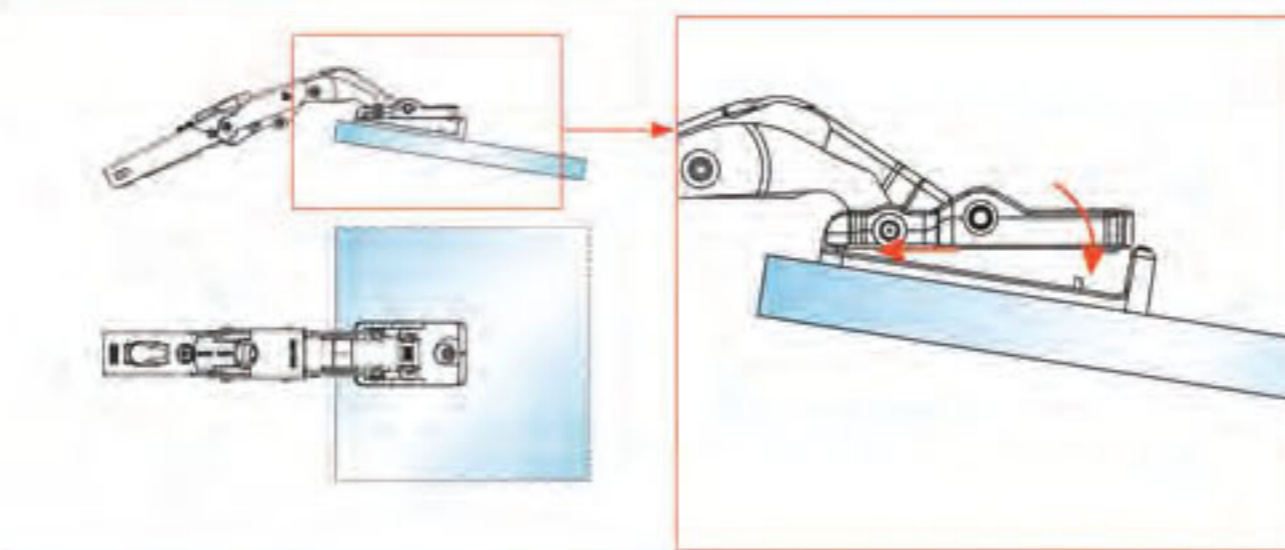

**2)** Locate the hinge onto the plate when it is bonded to the door.

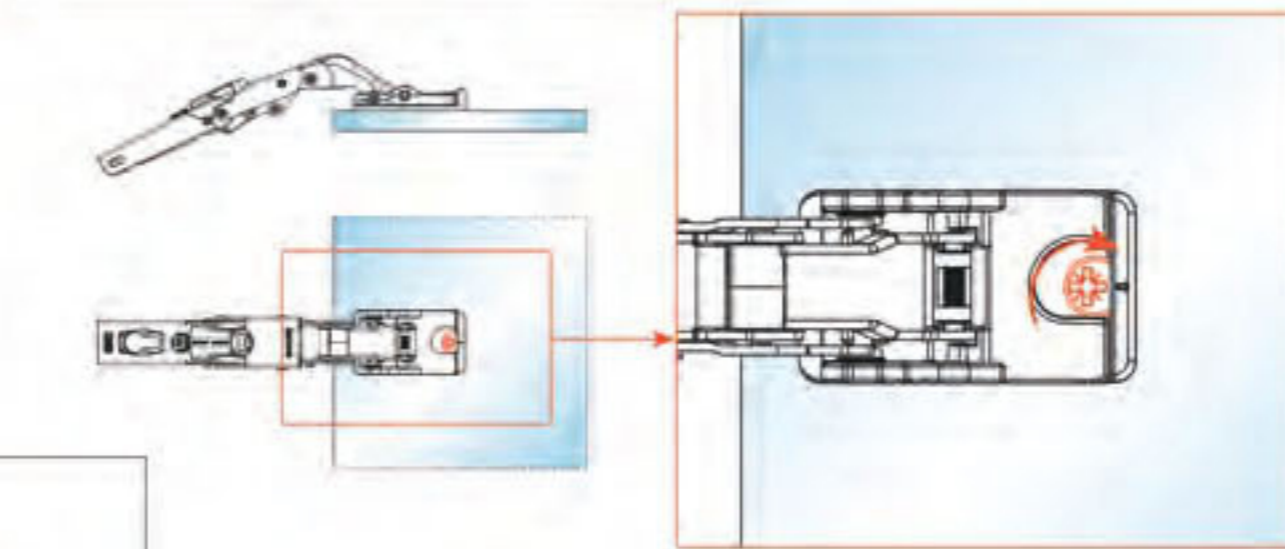

**3)** Rotate the fixing cam.

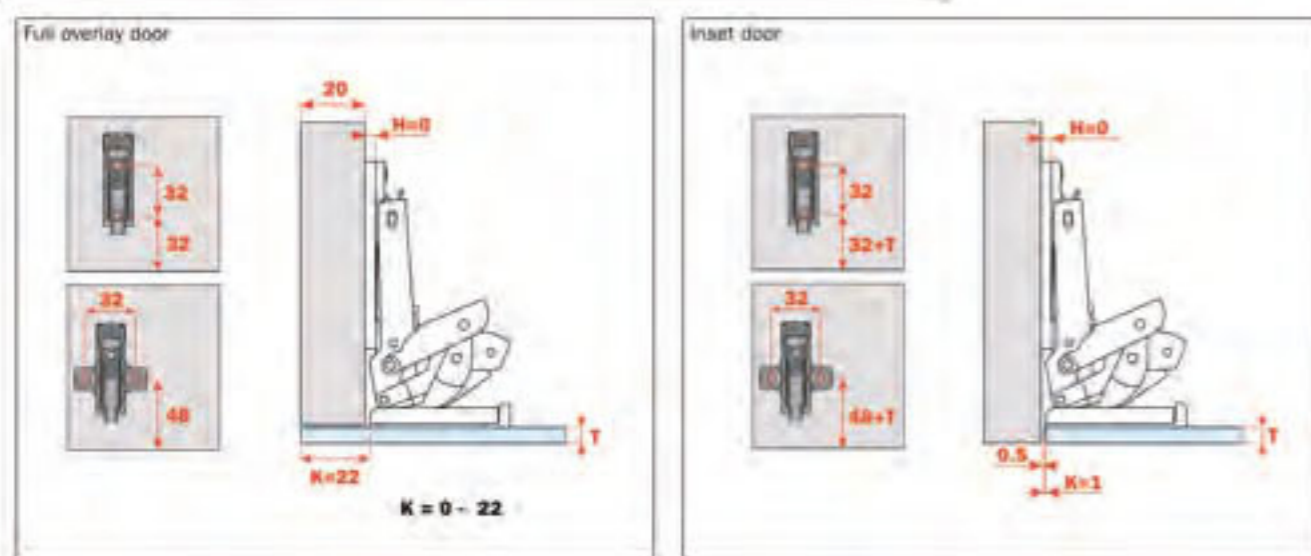
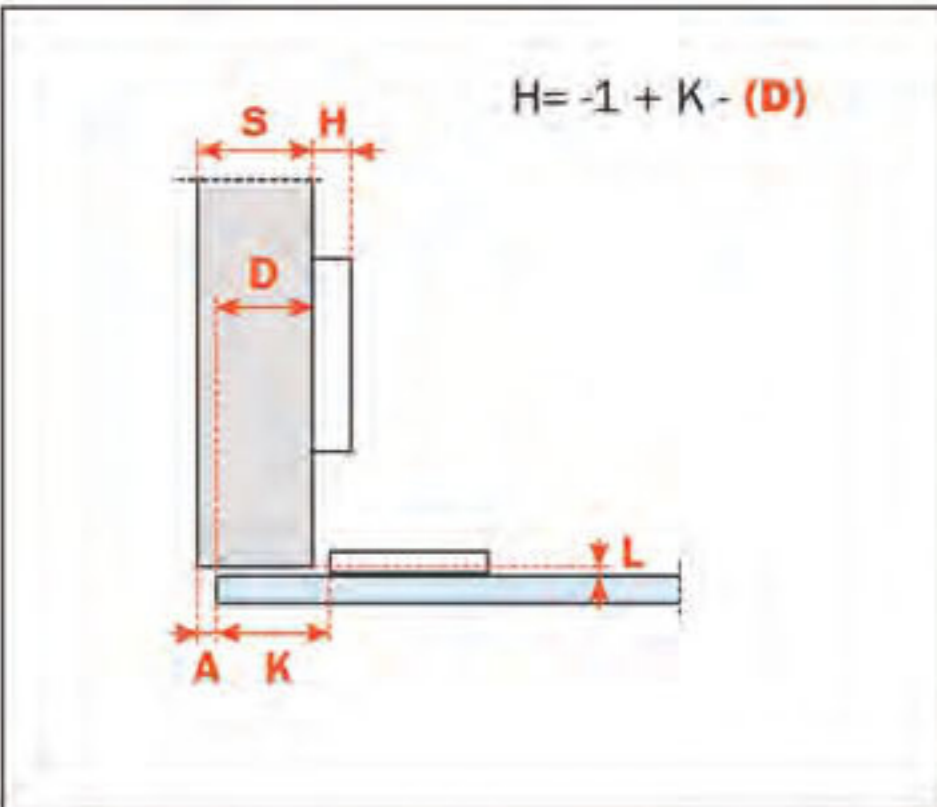

### Technical information

- Hinges for glass doors.
- No drilling of the glass is required.
- Possible fixing inset distance on the door (K): from 0 to 22 mm.
- 110° opening. With soft closing system
- Compatible with all traditional Series 200 mounting plates and with all Domi snap-on mounting plates.

### ข้อมูลทางเทคนิค

- บานพับสำหรับบานกระจกเปลือย
- ไม่ต้องเจาะกระจก (ใช้กาวยิวในการติดตั้ง)
- ระยะเปิด 110 องศา
- มีระบบปิดแบบนุ่มนวล
- สามารถใช้ได้ทั้ง “ตัวหนูนคลิบ” และตัวหนูนมาตรฐาน
- L ทับเต็มขอบ / K ทับครึ่งขอบ / N ในขอบ